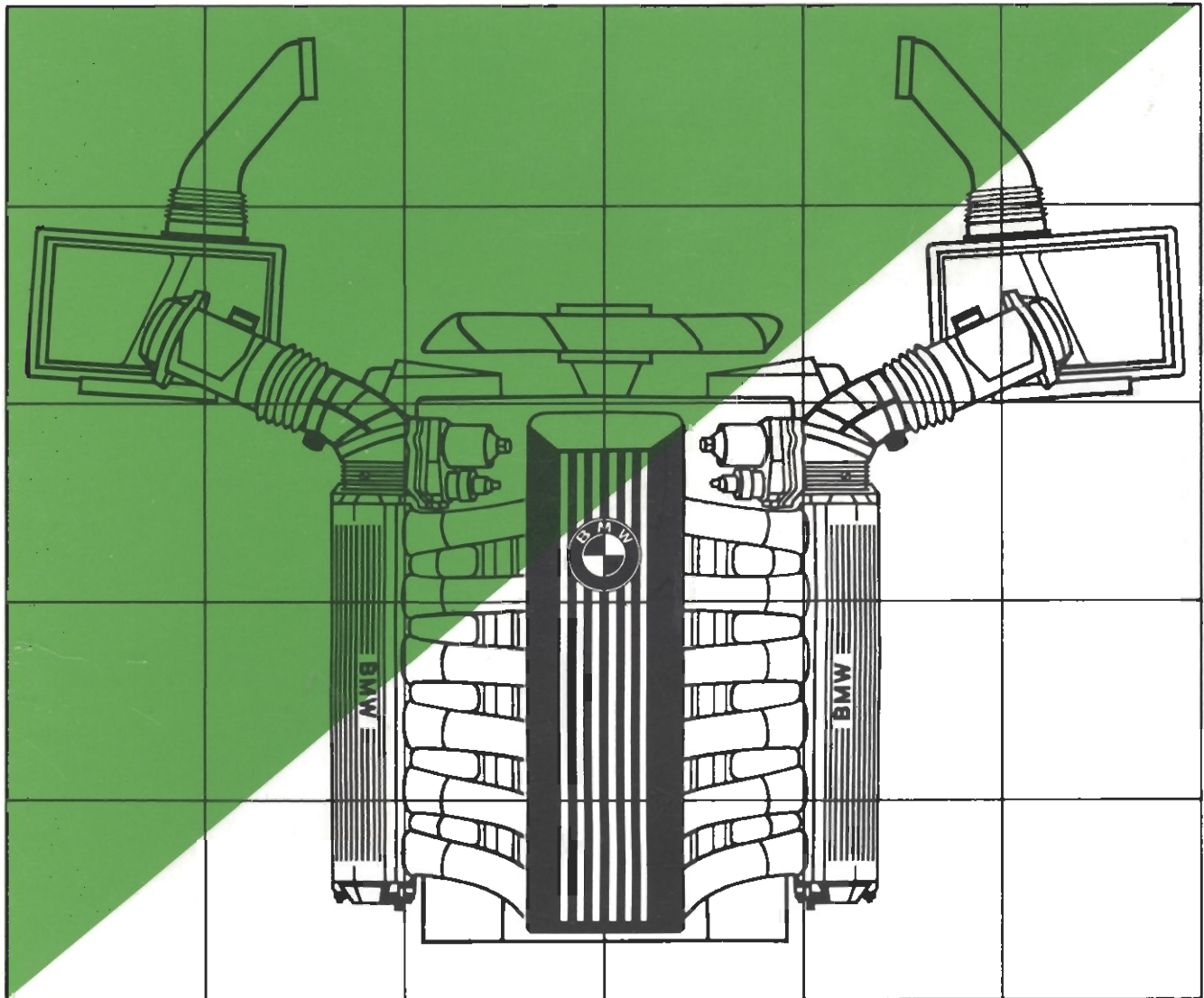
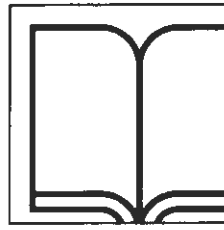


# BMW V-12 Light Alloy Engine M 70

# Training Course Material



# Information

The information in this training course brochure is for the exclusive use of participants of this training course in the BMW Service Training Centre.

Information updated to June, 1987.

Refer to the latest information published by the technical departments of the Service Division for additions and amendments to specifications.

# Contents

|       | Topic  | Page  |
|-------|--|-------|
| 1.    | <b>Introduction</b>  | 2     |
| 2.    | <b>Specifications — Engine</b>                                 | 3     |
| 3.    | <b>M 70 Concept</b>  | 4-6   |
| 4.    | <b>Engine</b>  | 7-21  |
| 4.1   | Crankcase  | 7-9   |
| 4.2   | Crankshaft   | 10    |
| 4.3   | Connecting Rods  | 11    |
| 4.4   | Bearings   | 12    |
| 4.5   | Pistons  | 13    |
| 4.6   | Cylinder Head  | 14-16 |
| 4.7   | Camshaft   | 17-19 |
| 4.8   | Charge Cycle   | 20    |
| 4.9   | Combustion Chamber Design                                      |       |
| 5.    | <b>Auxiliary Equipment, Oil Supply/Fuel/Air Supply Systems</b> | 22-39 |
| 5.1   | Auxiliary Equipment Drive                                      | 22-24 |
| 5.2   | Coolant System   | 25-27 |
| 5.3   | Oil Circuit  | 28-31 |
| 5.4   | Fuel Supply  | 32-33 |
| 5.5   | Air Guide, Hot Wire Air Volume Sensor                          | 34-37 |
| 5.6   | Exhaust System, Catalytic Converter                            | 38-39 |
| 6.0   | <b>Car Electrical System and Electronics</b>                   | 40-48 |
| 6.1   | Alternator, Battery, Starter and Ignition                      | 40-41 |
| 6.2   | Electronic Box   | 42    |
| 6.3   | Engine Control Management                                      | 43-46 |
| 6.3/1 | Motronics M 1.2  | 44    |
| 6.3/2 | EML  | 45    |
| 6.3/3 | ASC/ABS/MSR — Function   | 46    |
| 6.4   | Engine Data and Values   | 47    |
| 6.5   | Wiring Diagrams  | 48    |
| 6.6   | Tightening Torque — Engine Layout                              | 48    |

# 1. Introduction

Twelve-cylinder engines have a long tradition at BMW. BMW already produced a V-12 engine 60 years ago. It developed up to 750 HP (551 kW) and had a displacement of an enormous 47 litres. It was known as one of the best aircraft engines in the history of aviation. In 1930 a Dornier Wal used this engine to cross the Atlantic in 44 hours.

This was impressive proof of the dependability and quality of BMW engines.

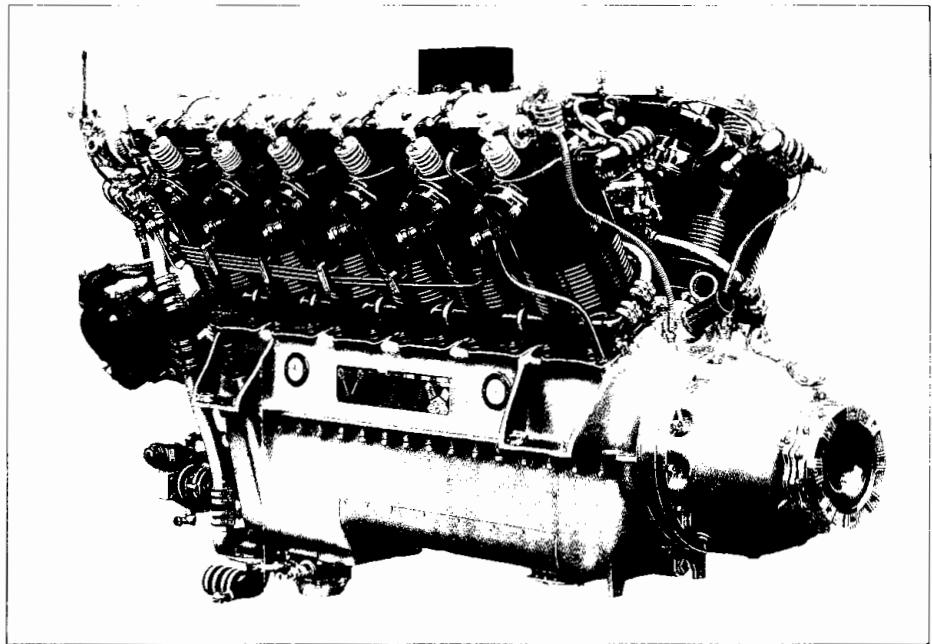


Fig. 1  
BMW 12 Cylinder Airplane Engine  
from 1927

BMW presented a new V-12 engine in 1979. It was based on the M 20 (2.3 litre) engine. It developed 275 HP/200 kW with a displacement of 4463 cm<sup>3</sup>.

It is time again in 1987:

BMW has developed a new, outstanding high performance engine, with design principles for the future, for the top model of the '7' series.

The BMW twelve cylinder engine — currently the most modern standard production engine in the whole world!

The BMW V-12 light alloy engine (M 70) — the first V-12 light alloy engine with catalytic converter!

## 2. Technical Data V-12 Engine

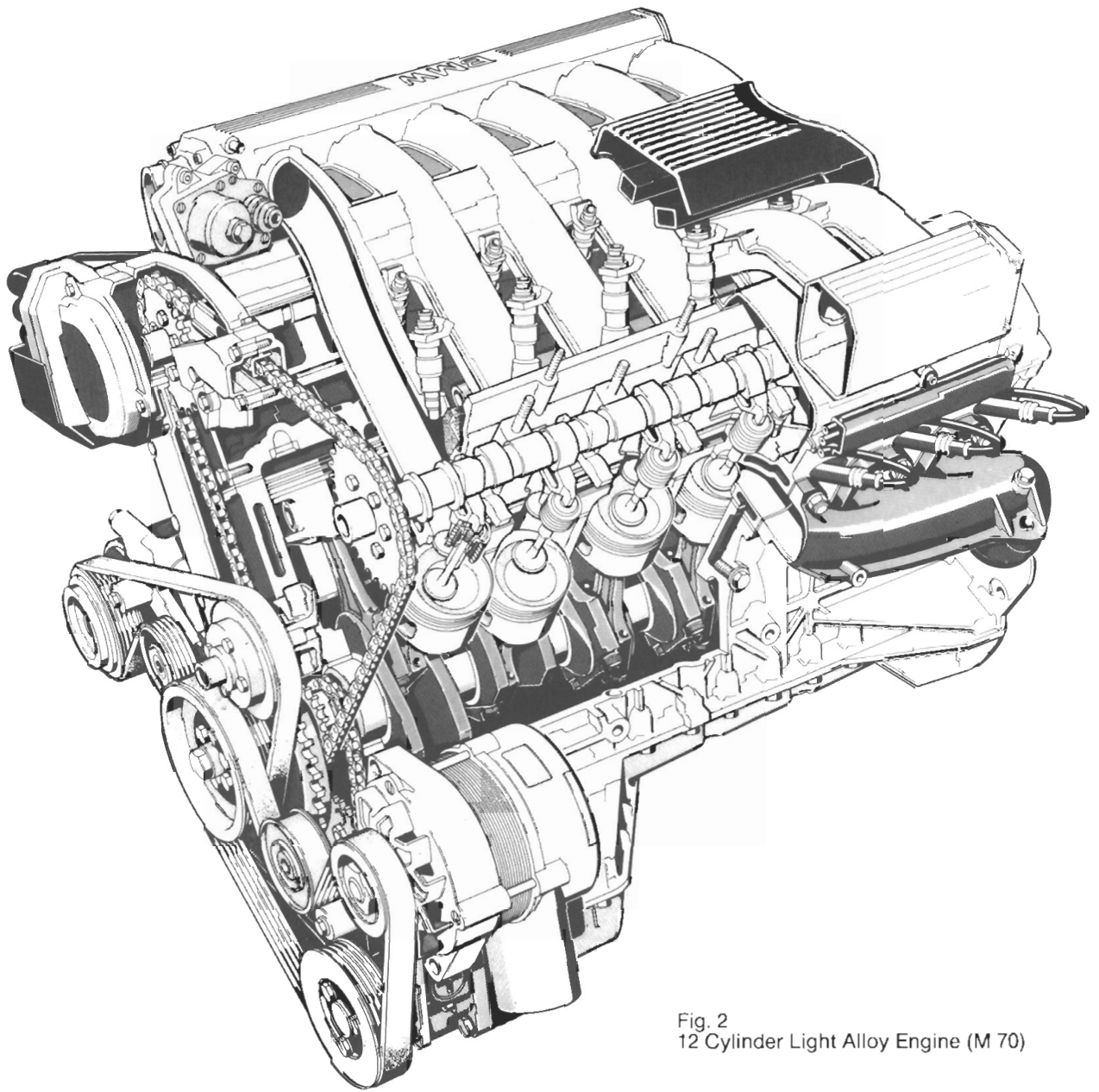


Fig. 2  
12 Cylinder Light Alloy Engine (M 70)

|                   |                            |                 |
|-------------------|----------------------------|-----------------|
| Displacement      | 4988                       | cm <sup>3</sup> |
| Bore              | 84                         | mm              |
| Stroke            | 75                         | mm              |
| Power             | 220/300                    | KW/HP           |
|                   | at 5200                    | rpm             |
| Torque            | 450                        | Nm              |
|                   | at 4100                    | rpm             |
| Compression ratio | 8.8 to 1                   |                 |
| Fuel              | Unleaded                   | regular         |
| Firing order      | 1-7-5-11-3-9-6-12-2-8-4-10 |                 |

# 3. Concept of M 70

## Objectives:

- High performance
- Extreme smooth running
- Good economy
- Up-to-date emission control
- Compact design
- Light weight
- Limited servicing

These objectives meant a special challenge for the engineers developing such a large, high performance car. BMW developed a concept for realization of these objectives. An engine developing approx. 200 kW requiring a displacement of approx. 5 litres. Both V-8 and V-12 engines could be applied in this range.

BMW decided in favour of a 60° V-12 engine for the following reasons.

- Limited forces of gravity due to small cylinder units.
- Short flame travel due to small cylinder units and therefore realization of high compression ratios.
- Small ignition spacing, so that uniform engine torque is reached.

Smooth running also means keeping noise levels outside and inside of the car as low as possible. The volume of oscillating and rotating mass is especially important in this case. Mass transmits internal forces and moment into the engine, which will then also have an acoustic effect. This is why BMW decided for small units.

The aluminium/light alloy crankcase is lightweight and axle load division is optimal. This guarantees good handling of the car.

The new BMW cylinder head design makes it possible to have high specific power output with high specific work.

Servicing M 70 engines is reduced due to the application of most modern technologies.

- Hydraulic valve clearance compensators simplify servicing.
- Auxiliary equipment is driven via multi V belts which do not require servicing.

The timing concept of the V-12 is completely new. Each bank of cylinders has its own independent Digital Motor Electronics. One of the many advantages of this conception is a precise definition of the air flow rate even in partial load range.

Both banks of cylinders can function as independent engines. If one cylinder bank should fail, the other bank of cylinders would still produce the power of a normal six cylinder engine.

The engine power is regulated with EML via drive motors on the throttle valves.

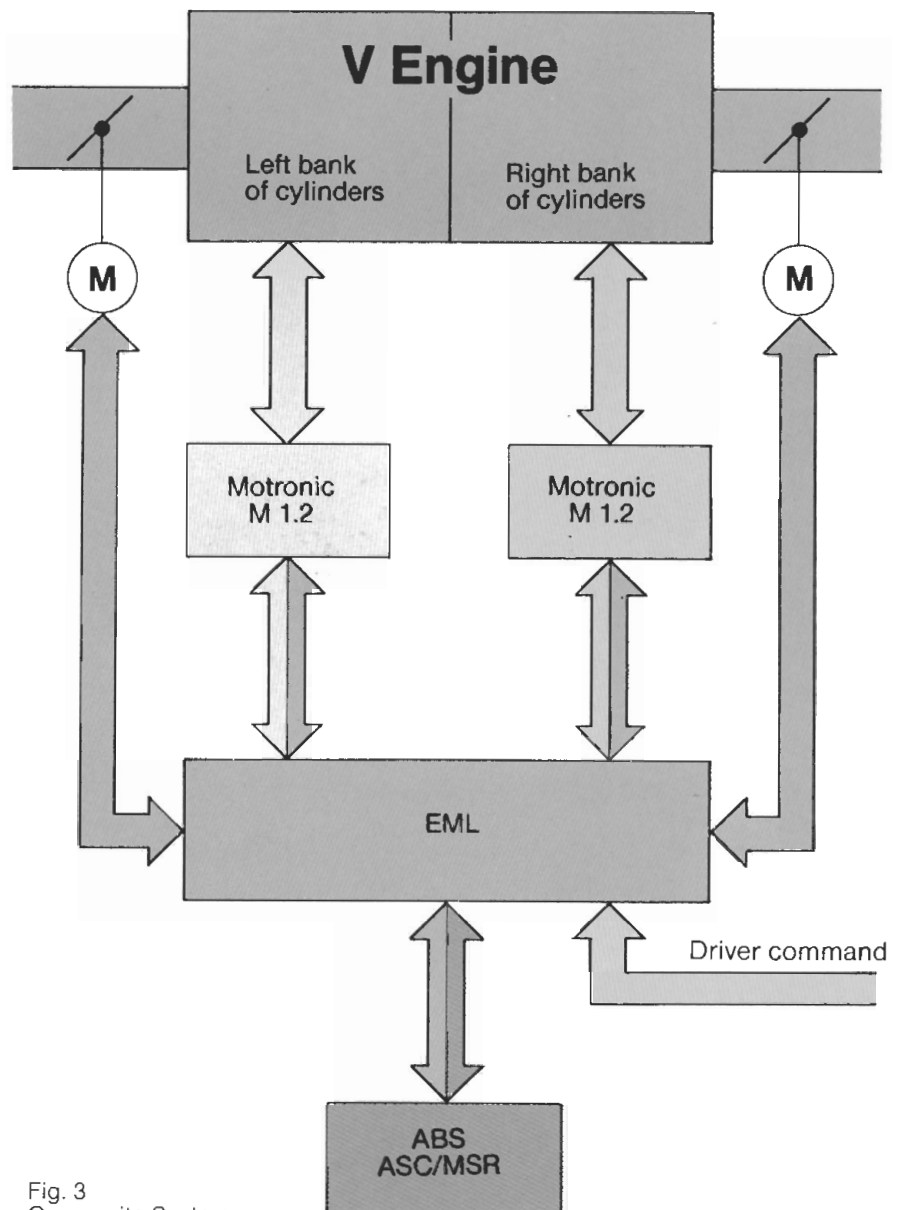


Fig. 3  
Composite System  
M 70 Engine Timing

# BMW V-12 Light Alloy Engine M 70

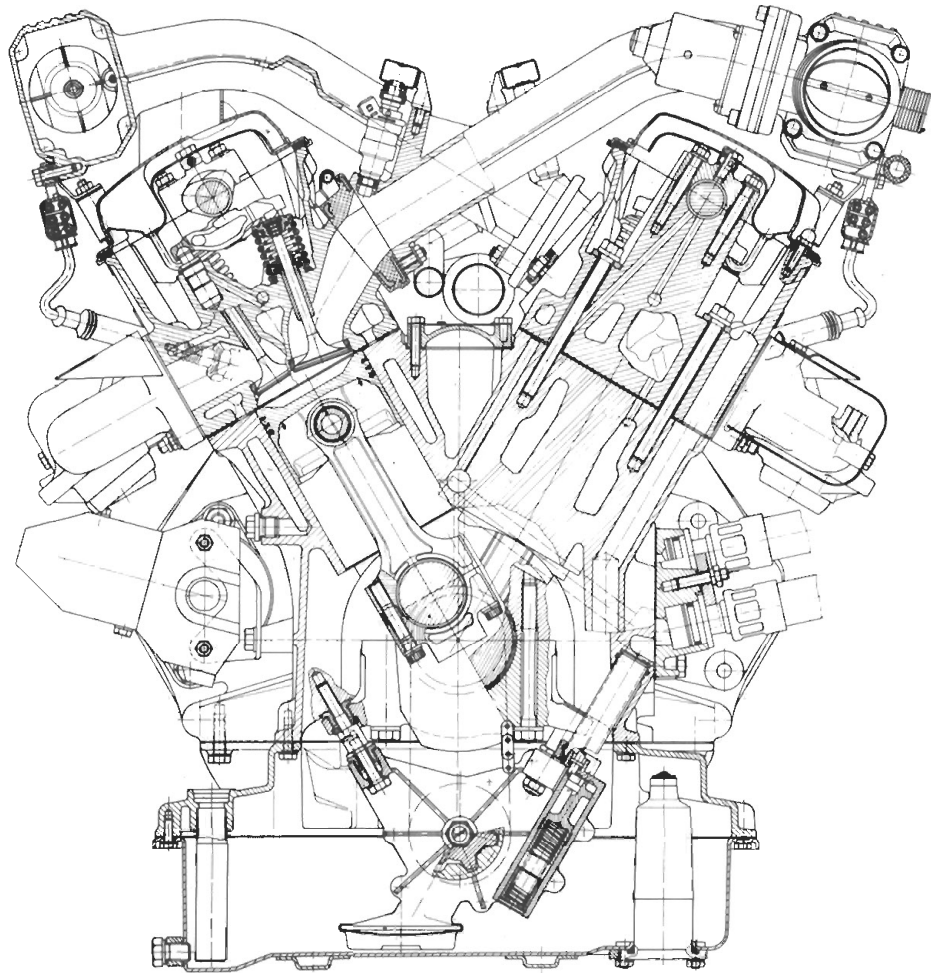


Fig. 4  
Section Drawing of V-12  
Light Alloy Engine

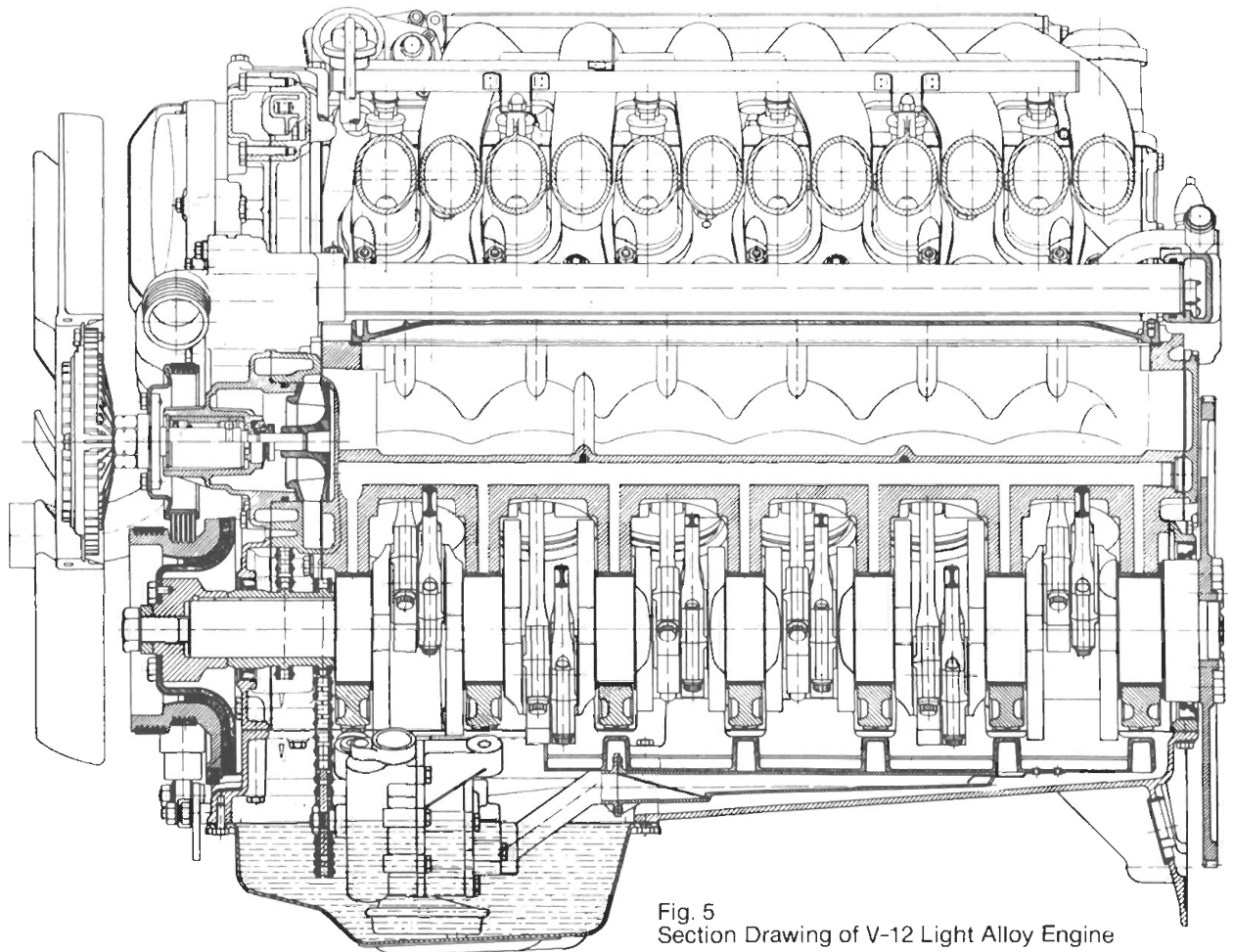


Fig. 5  
Section Drawing of V-12 Light Alloy Engine



# 4. Engine

## 4.1 Crankcase

The BMW V-12 engine has a light alloy crankcase made of an aluminium/silicium alloy. The share of silicium is approximately 17%. The weight of a finished machined crankcase is about 39 kg. The V-12 engine has 25 kg less weight as compared with the conventional grey cast iron block of the BMW 3.5 litre engine.

Major sizes of the small six cylinder engine series are used.

|                  |       |
|------------------|-------|
| Cylinder spacing | 91 mm |
| Bore diameter    | 84 mm |
| Stroke           | 75 mm |

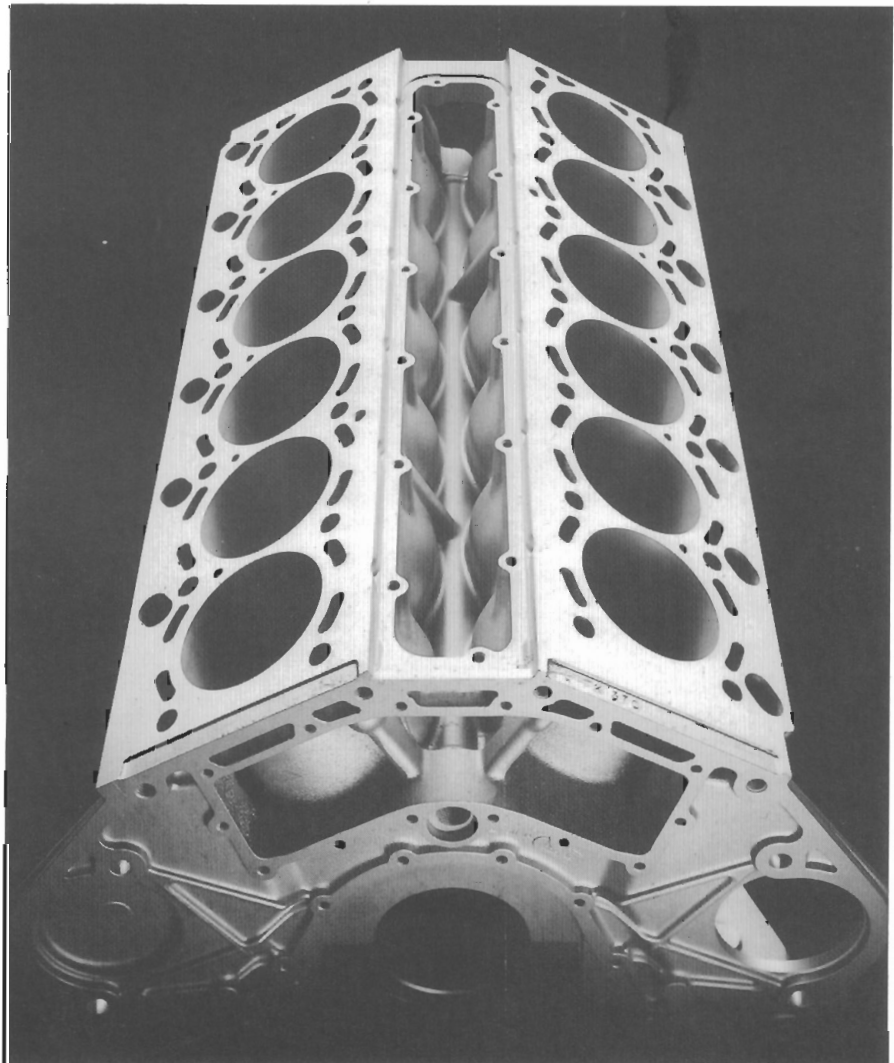


Fig. 6  
Crankcase of V-12 Engine

Banks of cylinders are arranged to each other in a V-angle of 60°.

The crankcase is manufactured using a pressure diecasting method.

Cylinder barrels themselves are manufactured with a special method. Therefore the pulling in and sealing of cylinder liners has been omitted. The iron-coated aluminium pistons run direct in the uncoated bores. The share of silicium in the crankcase is guarantee for low wear of cylinder barrels.

Usually light alloy crankcases will be pressure diecast without the use of sand cores. This led to the so-called OPEN TOP solutions with free-standing cylinder liners. Strength is given priority over this more simple manufacturing method for V-12 engines. Consequently the crankcase is designed with an upper cover for each bank of cylinders (CLOSED TOP).

Both banks of cylinders are interconnected in a V-angle by a land and contribute to the good flexional strength in the engine/transmission assembly.

Annealed cast iron main bearing caps are mounted on the crankcase with 4 bolts. Two bolts each are perpendicular to the cylinder dividing plane and parallel to the cylinder axis. In this manner forces of gas and gravity are transmitted into the crankcase on a wide basis.

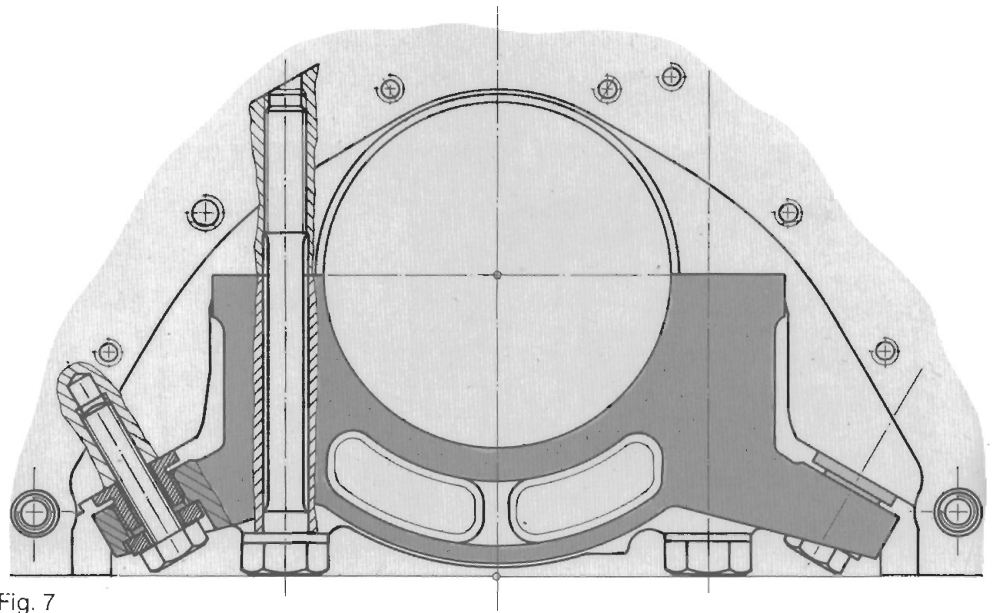


Fig. 7  
Bearing Cap Installation on V-12 Engine

There is a large and flexionally strong basis for bolting on the transmission by way of the

- rear oil pan end and
- flange for bolting on the starter

The bolting flange is cast on the crankcase on both sides. The method of starter installation can be selected to conform with the country version of the car.

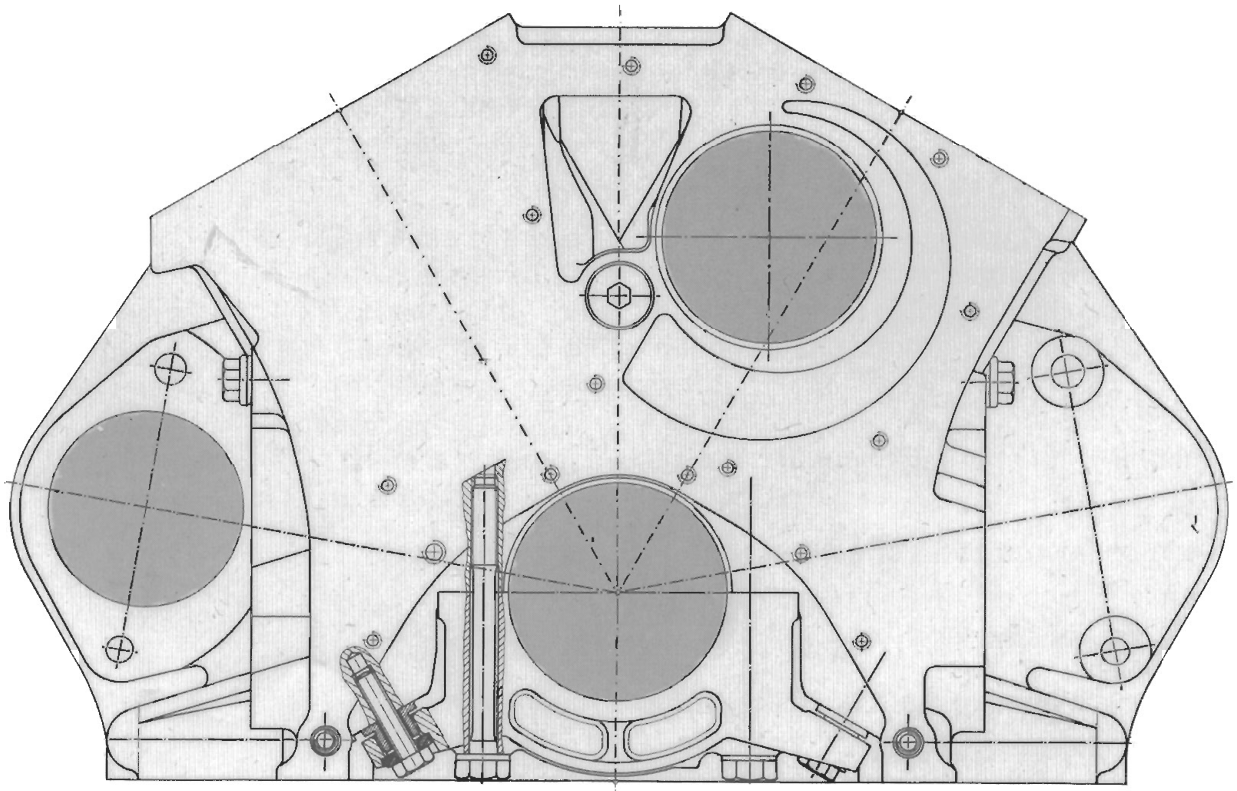


Fig. 8  
View of Power Output End of V-12 Engine

## 4.2 Crankshaft

Noise and oscillating behaviour of an engine depend on the flexional strength of its crankshaft to a considerable extent.

The short stroke conception of the M 70 engine determined the design of the crankshaft. The seven bearings of the crankshaft and a crank angle of  $120^\circ$  produce good flexional strength.

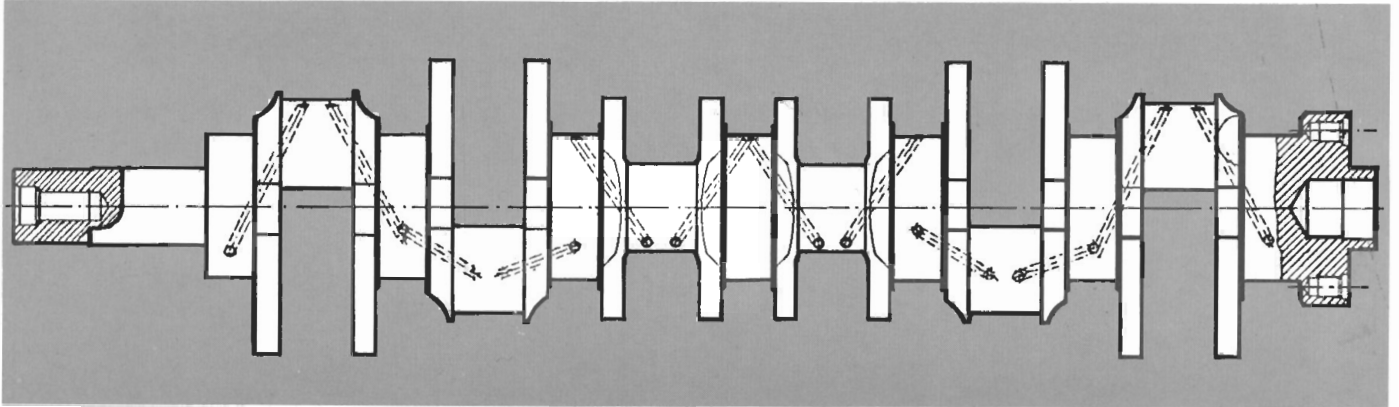


Fig. 9  
Section View of V-12 Engine Crankshaft

Through journals are pebble finished. This means:

- good surface finish,
- tight bearing clearance tolerances and
- uniform good noise behaviour of crankshaft.

The crankshaft is forged from material CK 45.

## 4.3 Connecting Rods

Two connecting rods are mounted on each crankshaft journal. Each connecting rod is forged as also in 2.5 litre engines of the small six cylinder series. Outside surfaces of the big end of the connecting rods are machined.

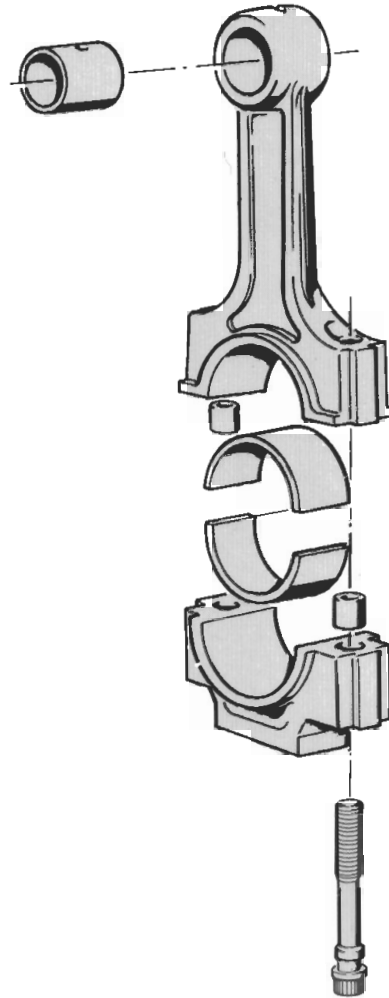


Fig. 10  
V-12 Engine Connecting Rod

**Size:**  
Length between big and small  
end centres = 135 mm

The connecting rods of cylinders 7-12 are mounted on the rear throw journal; consequently there is displacement to the connecting rods (pistons) of the first bank of cylinders (cyl. 1-6).

### Shop Info



Because of this displacement the cylinder head is offset 17 mm toward the rear from the second bank of cylinders (cyl. 7-12). Consequently there are also different cylinder head gaskets. Camshafts also differ in length. The shorter one is in the first bank of cylinders (cyl. 1-6):

There is different installation of connecting rods for cylinders 1-6 and 7-12.

- Cylinder bank 1-6: Boss on big end faces the timing chain end.
- Cylinder bank 7-12: Boss on big end faces the flywheel end.
- The machined outside surface on the big end always faces out.

## 4.4 Bearings

Main and connecting rod bearing shells are triple-material bearings as used in the BMW turbocharged diesel engine. The pilot bearing is located on the clutch end.

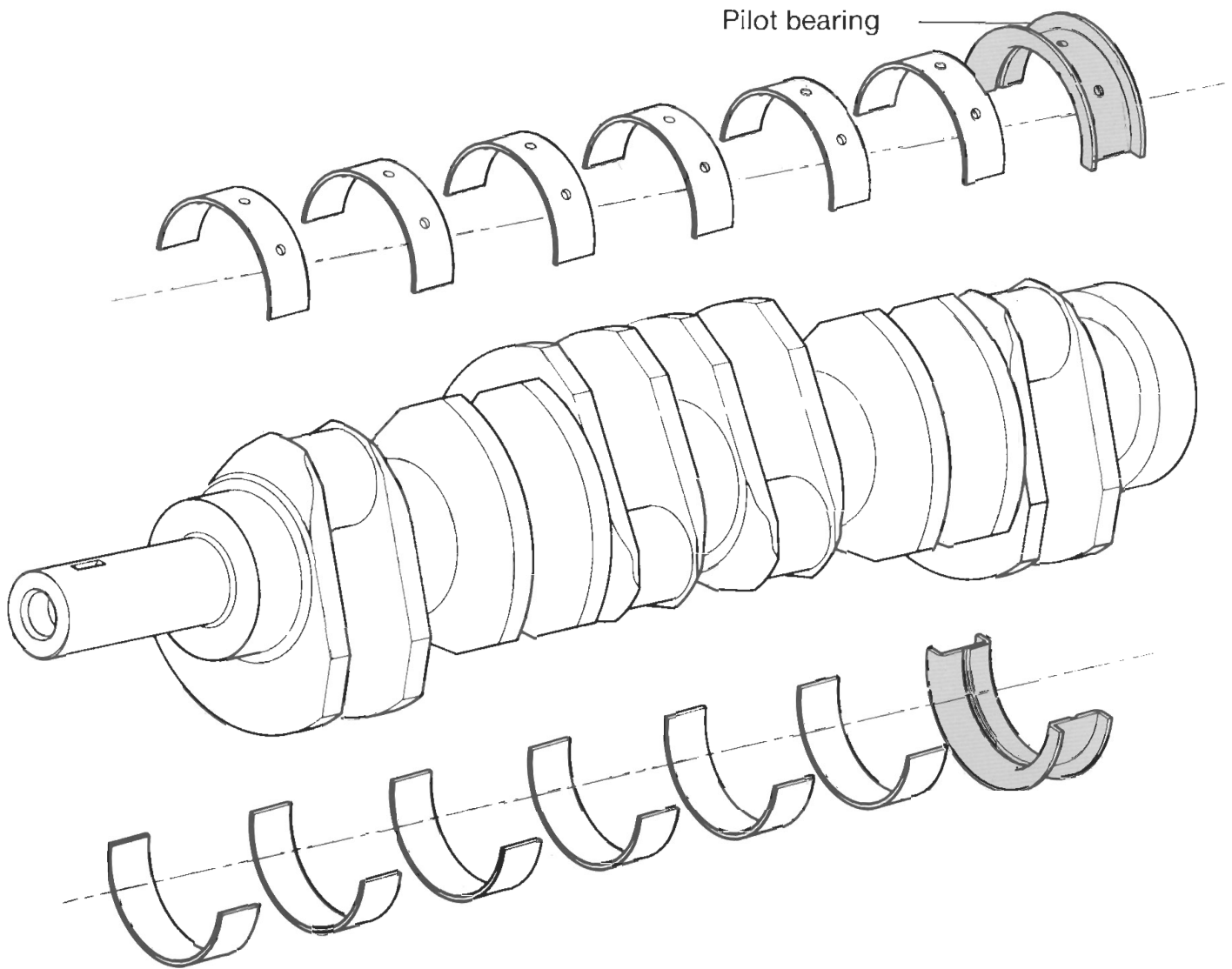


Fig. 11  
Main and Connecting Rod  
Bearing Shells

**Sizes**

Main Bearings: Width 22.6 mm  
Diameter 75 mm

Conrod Bearings: Width 16 mm  
Diameter 45 mm

## 4.5 Pistons

The light weight pistons are made of aluminium and have a 1/10th mm thick iron coat. They run direct in the aluminium crankcase.

The piston crown has a combustion chamber well, which is offset in direction of the spark plug. Consequently pistons of left and right cylinder banks are different.

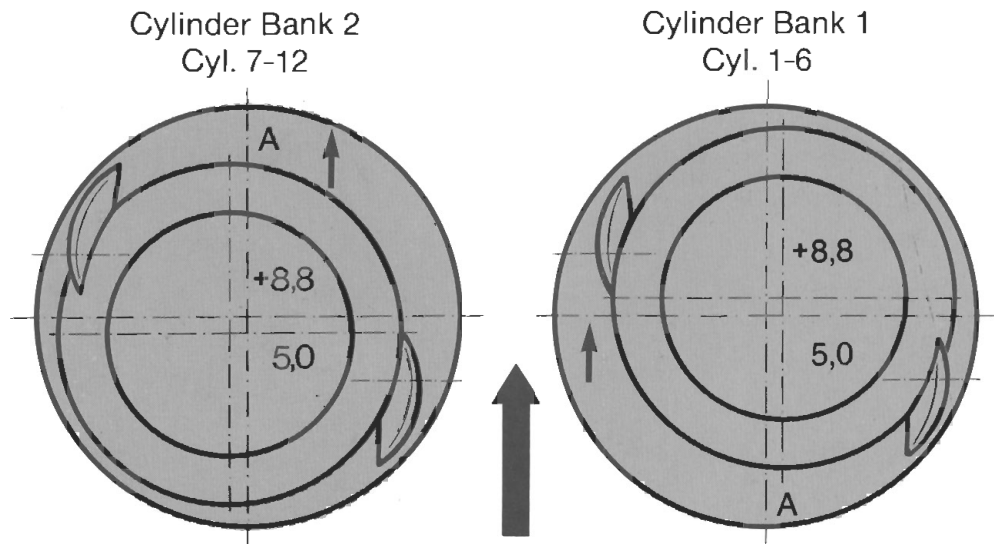


Fig. 12  
V-12: Piston Crown View

## Shop Info



- Cylinders 1-6: Pistons installed with well facing forward and out.
- Cylinders 7-12: Pistons installed with well facing back and out.
- Note installed position of connecting rods!

## Piston Rings

1st groove: Plain compression ring with internal chamfer and crowned, chrome plated bearing surface

2nd groove: Tapered face compression ring

3rd groove: Bevelled oil scraper ring with rubber lined spring

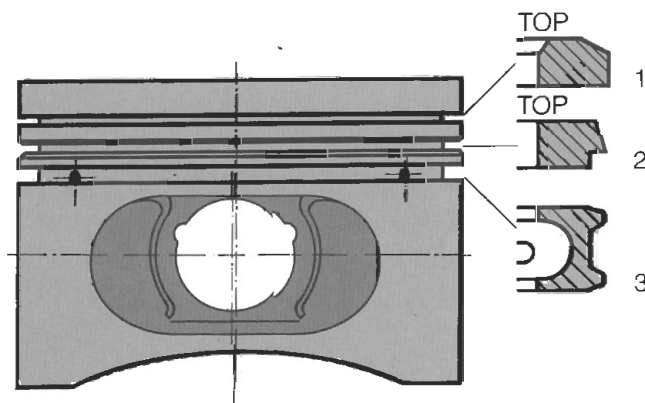


Fig. 13  
V-12 Pistons and Piston Rings

## 4.6 Cylinder Heads

The pressure diecast aluminium cylinder heads for cylinders 1-6 and 7-12 are completely identical. The compression pressure and compression ratio only have slight tolerances.

The reasons for this are:

- the electrochemically machined combustion chamber wells and
- the double-classified cylinder head gaskets.

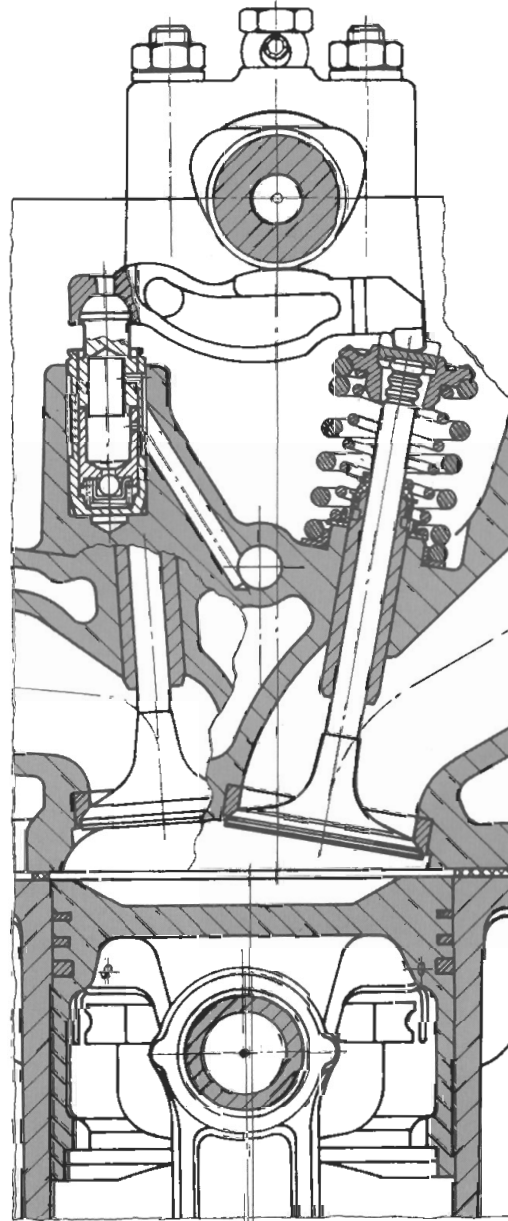


Fig. 14  
Valve Drive and Combustion Chamber

## Cylinder Head Gaskets

Gaskets are fundamentally different for cylinders 1-6 and 7-12.

Each gasket is marked with the words "TOP" and "FRONT".

Therefore mix-ups during installation are excluded.

Gaskets are available in two different thicknesses depending on the amount of measured piston protrusion. They are marked with one or two holes on the end of the gasket. It is therefore possible to note the thickness from the outside.

**Cylinder head covers** have a sandwich design (metal/plastic/metal) for suppression of noise.

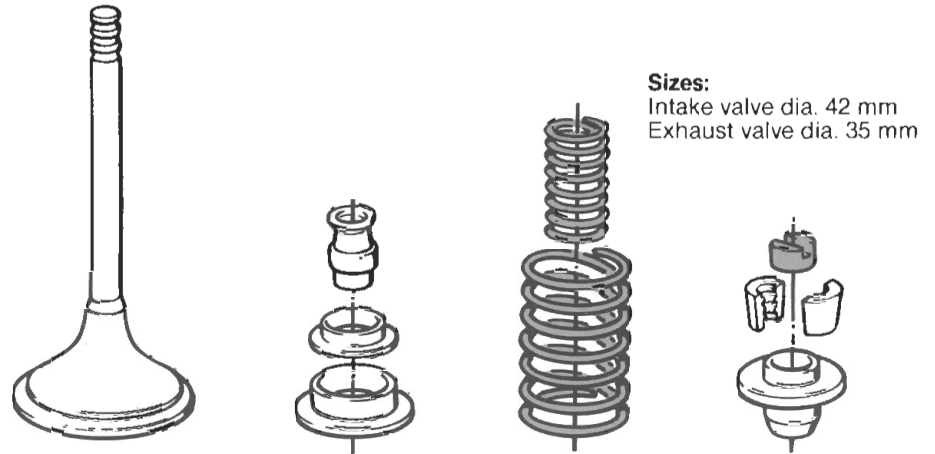


# Valves

Valves are operated with help of rocker arms. They are arranged in a V-angle of  $14^\circ$ . Each valve has two springs to reduce the high oscillation during valve operation.

The name of the valve material is nimonic.

The thrust piece serves to increase the surface of the valve and as a guide for the rocker arm.



Sizes:  
Intake valve dia. 42 mm  
Exhaust valve dia. 35 mm

Fig. 15  
Valve Operating Components

The lift of intake/exhaust valves is the same, namely 10.6 mm for both. However, valve lift operation is different. Inclination is  $104^\circ$  for intake and  $108^\circ$  on crankshaft for exhaust.

## Rocker Arms

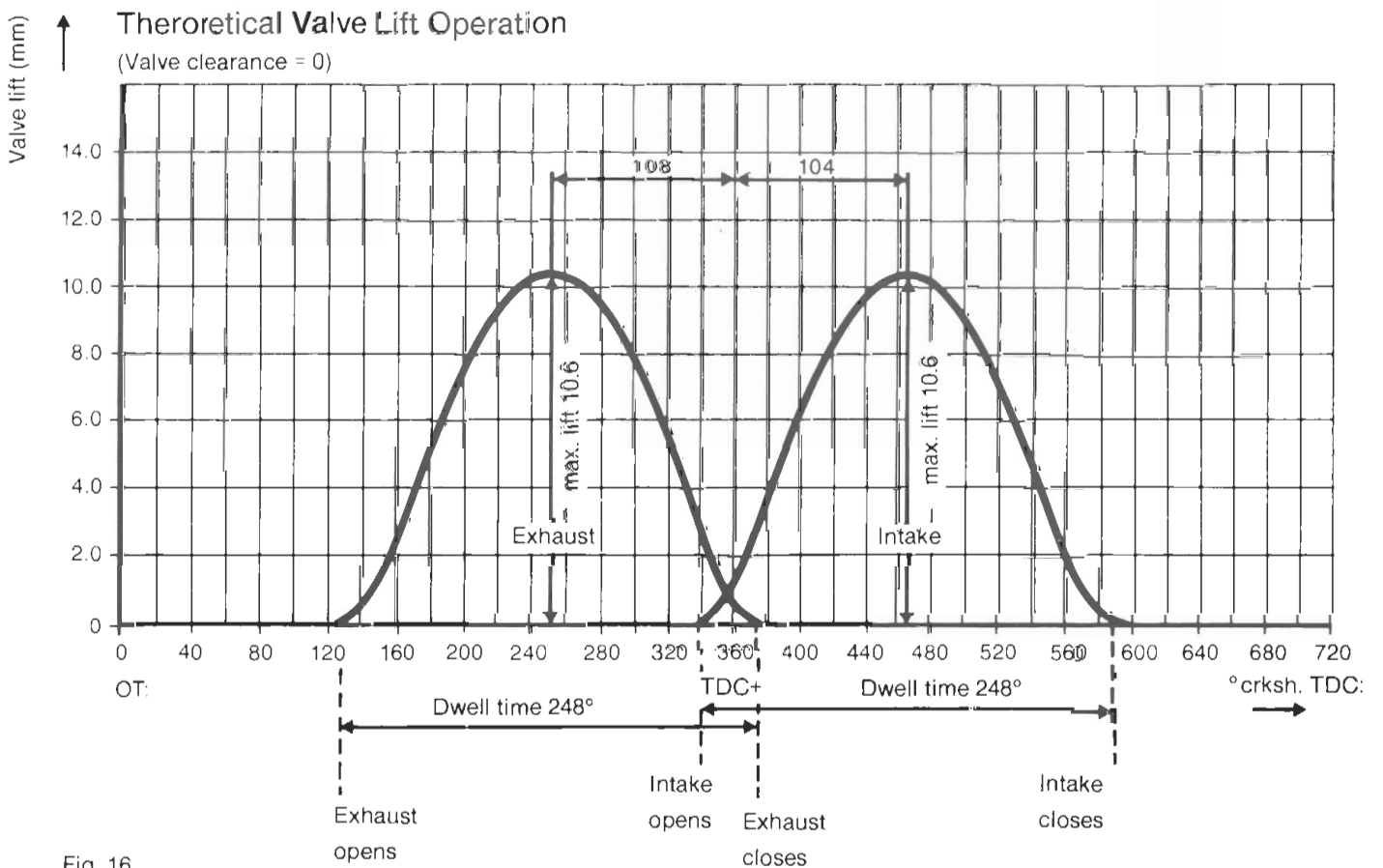


Fig. 16  
Theoretical Valve Lift Operation

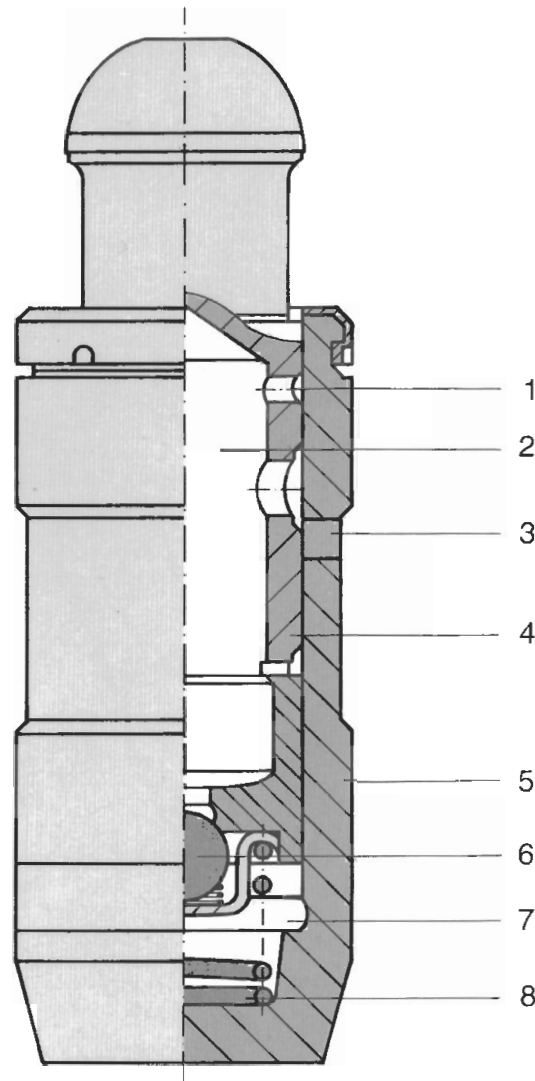
## Rocker Arms

The rocker arms for valves are clear chilled castings. They bear on the hydraulic valve clearance compensators. Long valve lift and short valve dwell times are made possible and affect a full torque development with high power output.

## Hydraulic Valve Clearance Compensators (HVA)

The compensators guarantee correct valve clearance without servicing. They work according to the principle of hydraulics.

- Hydraulic fluid is exchanged between a supply chamber and high pressure chamber.
- An internal piston bears on the lubricating oil cushion of the high pressure chamber. Oil displacement values are given.
- Certain influences (e.g. heat) could change the oil volume in the high pressure chamber.
- There is compensation for this change, if excessive oil escapes through a leak gap into the supply chamber.
- This oil drainage can be balanced out, if a return spring presses the piston up. Oil then flows back into the high pressure chamber via a ball-type check valve.



- 1 Bleeder bore
- 2 Oil supply chamber
- 3 Oil supply bore
- 4 Piston
- 5 Body
- 6 Ball-type valve
- 7 High pressure chamber
- 8 Spring

Fig. 17  
Compensator Section View

## 4.7 Camshaft

Two overhead camshafts control the valves. Both of them run on seven bearings each, however, they differ in length and design. The camshaft for cylinder bank 7-12 is longer because of the wide connecting rod displacement.

Camshafts are lubricated via spray plates, which are supplied with oil from the bearing seats.

|                                   |                 |
|-----------------------------------|-----------------|
| Dwell time of both camshafts:     | 248° crankshaft |
| Injection timing of intake side:  | 104° crankshaft |
| Injection timing of exhaust side: | 108° crankshaft |

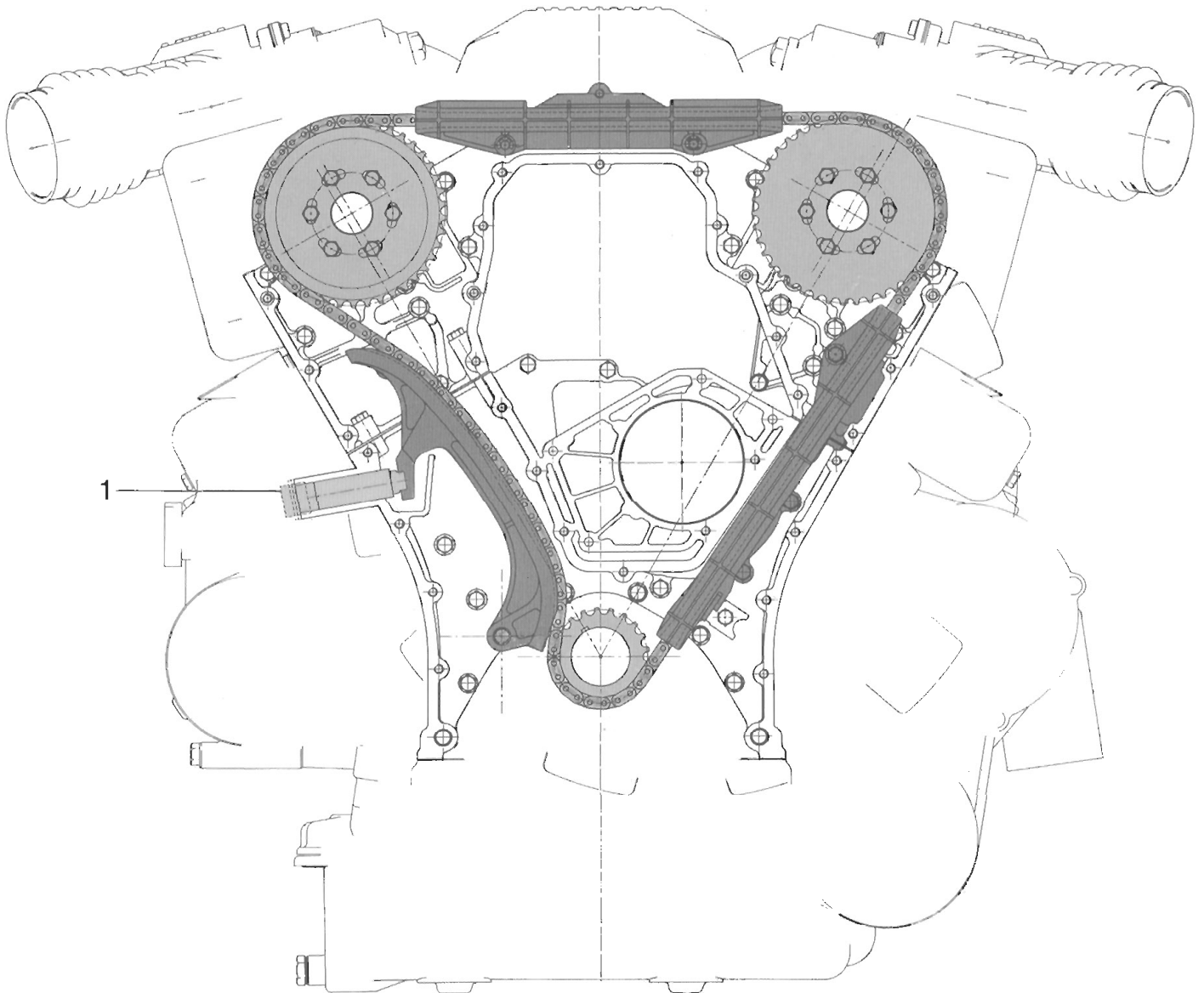
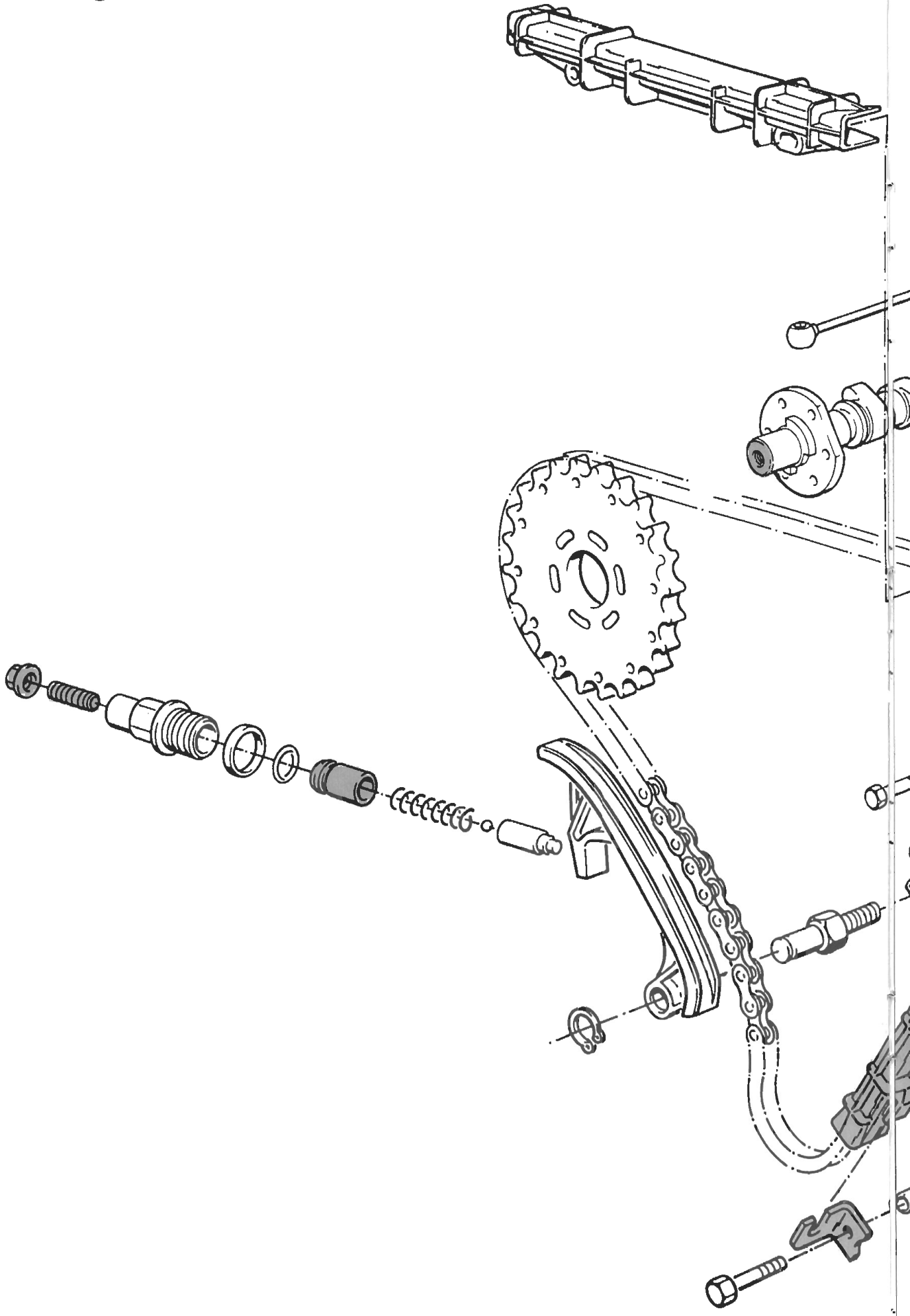


Fig. 18  
Engine Timing

Both camshafts are driven by a single roller chain (Simplex) on sprockets. Occurring chain oscillation is suppressed with plastic coated guides. Chain links are precision blanks, in order to guarantee a long service life for the guides. The adjustable chain tensioner (1) is located on the loose side of the belt.

# Valve Timing M 70



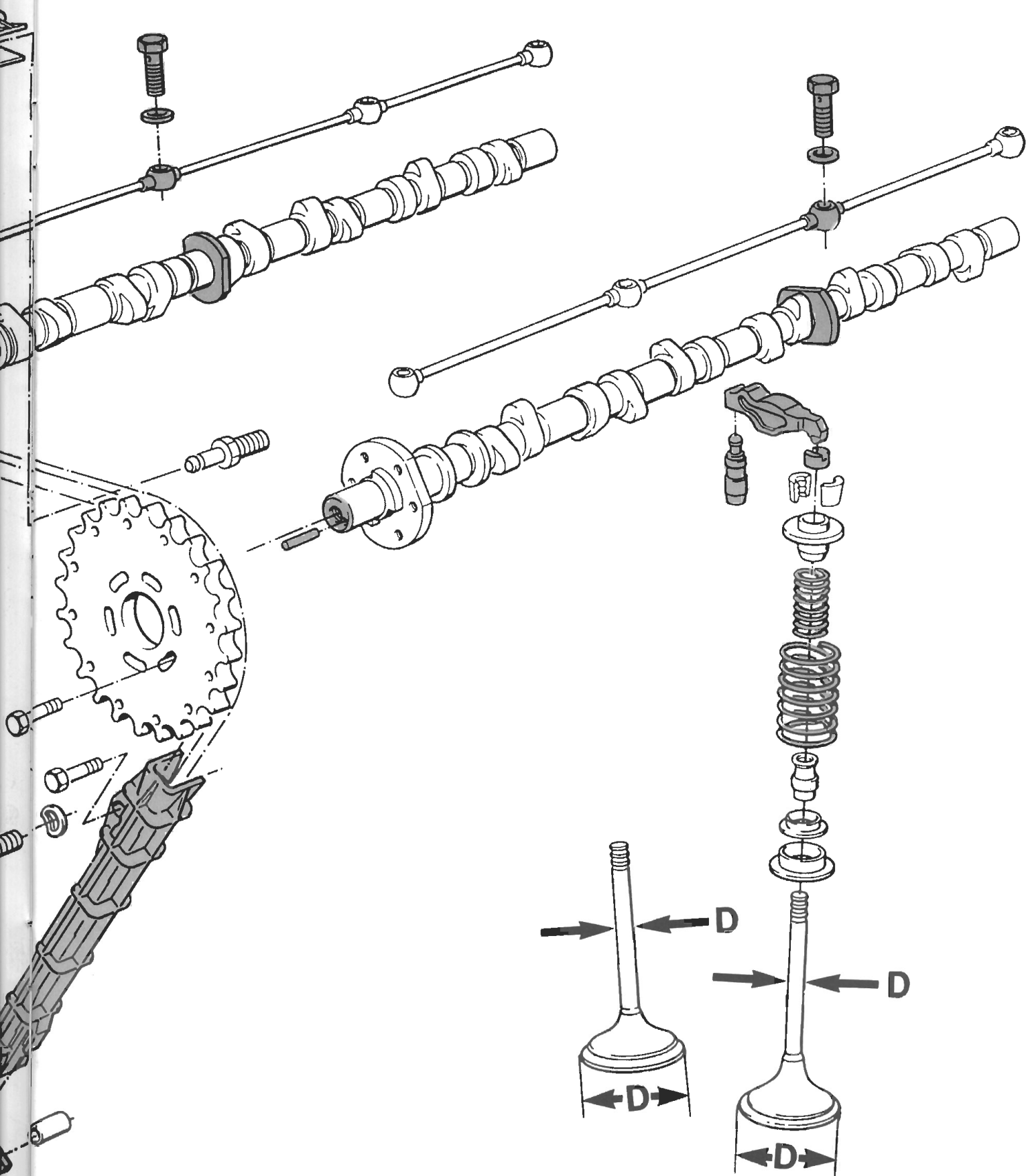


Fig. 19  
Valve Timing Component Survey  
V-12 Engine

# 4.8 Charge Cycle

The BMW V-12 engine develops its high specific power output with very favourable torque.

Requirements for this:

- Aerodynamic design of charge cycle ports
- High dynamic strength of valve drive
- Design of intake and valve position

Shorter timing is possible at equal maximum speed with the new valve timing — different timing angle of 108 crankshaft degrees for intake and 104 crankshaft degrees for exhaust with a valve lift of 10.6 mm. Both hot wire air flow sensors considerably reduce the amount of loss during charge cycles.

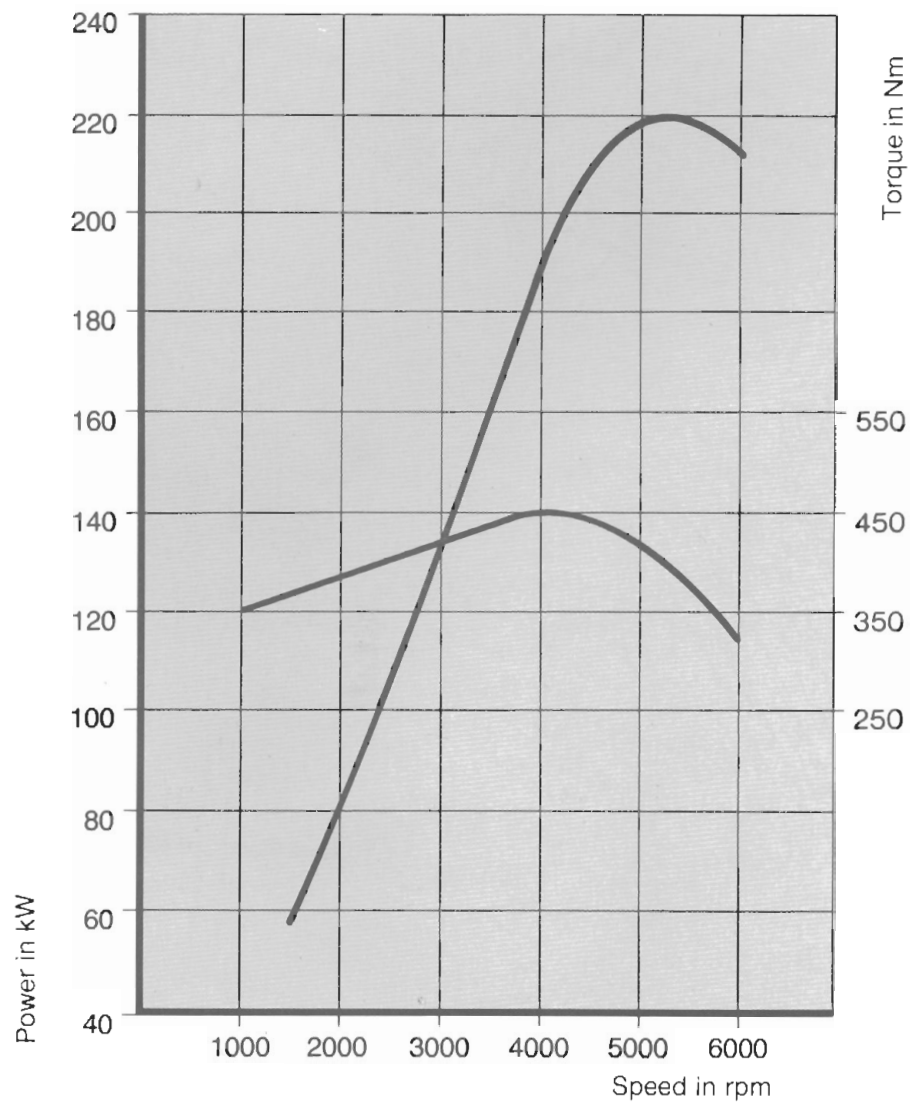


Fig. 20  
Torque/Power Diagram

## 4.9 Combustion Chamber Design

The design of the combustion chamber produces a favourable surface-to-volume ratio. The largest part of the fuel/air mixture is positioned directly below the spark plug because of the piston well. A large quench area is produced by displacing the trapezoidal well towards the spark plug. It is located on the side of the spark plug facing away.

Consequently the favourable compression ratio of 8.8 to 1 is reached even with high charging and design for unleaded RON 91 gasoline.

Combustion chamber volume =  $53.3 \text{ cm}^3$ .

Camshafts:

Intake  $248^\circ/104^\circ$

Exhaust  $248^\circ/108^\circ$

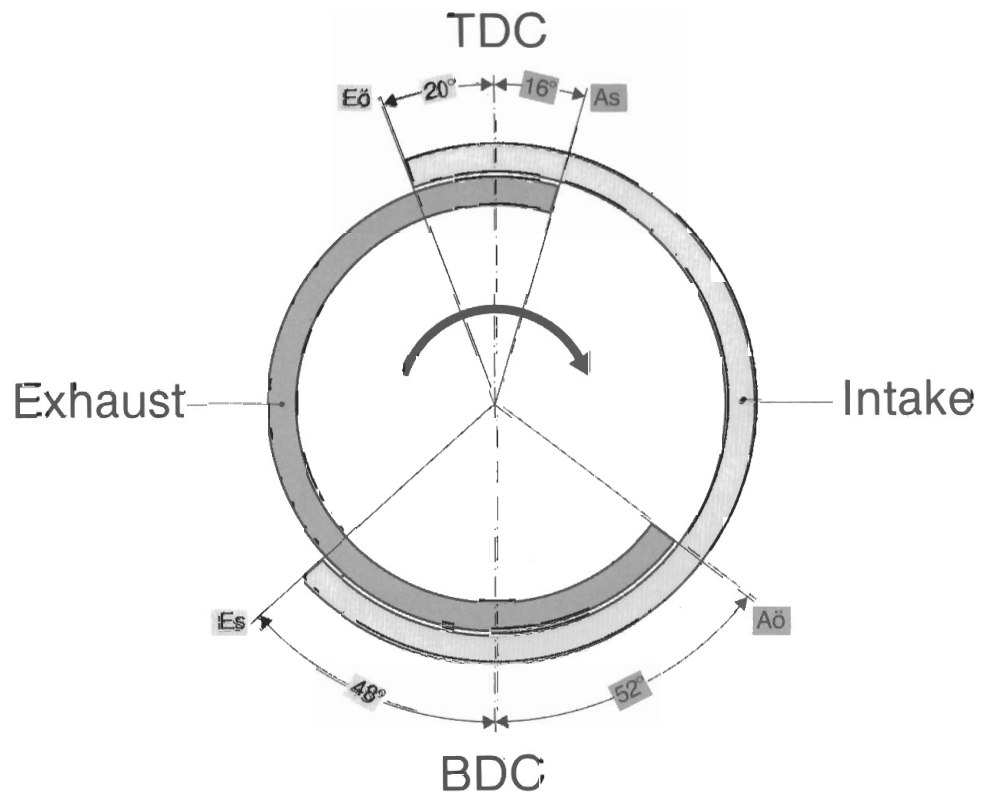


Fig. 21  
M70 Timing Diagram

# 5. Auxiliary Equipment Parts, Oil Supply/ Fuel/Air Supply and Exhaust Systems

## 5.1 Drive of Auxiliary Equipment Parts

Auxiliary equipment is driven off of the crankshaft pulley in two separate arrangements.

- The first drive circuit is for the air conditioner compressor and water pump with fan.
- The second drive circuit is for the alternator and a tandem hydraulic pump serving power steering, brake booster and ride level control.

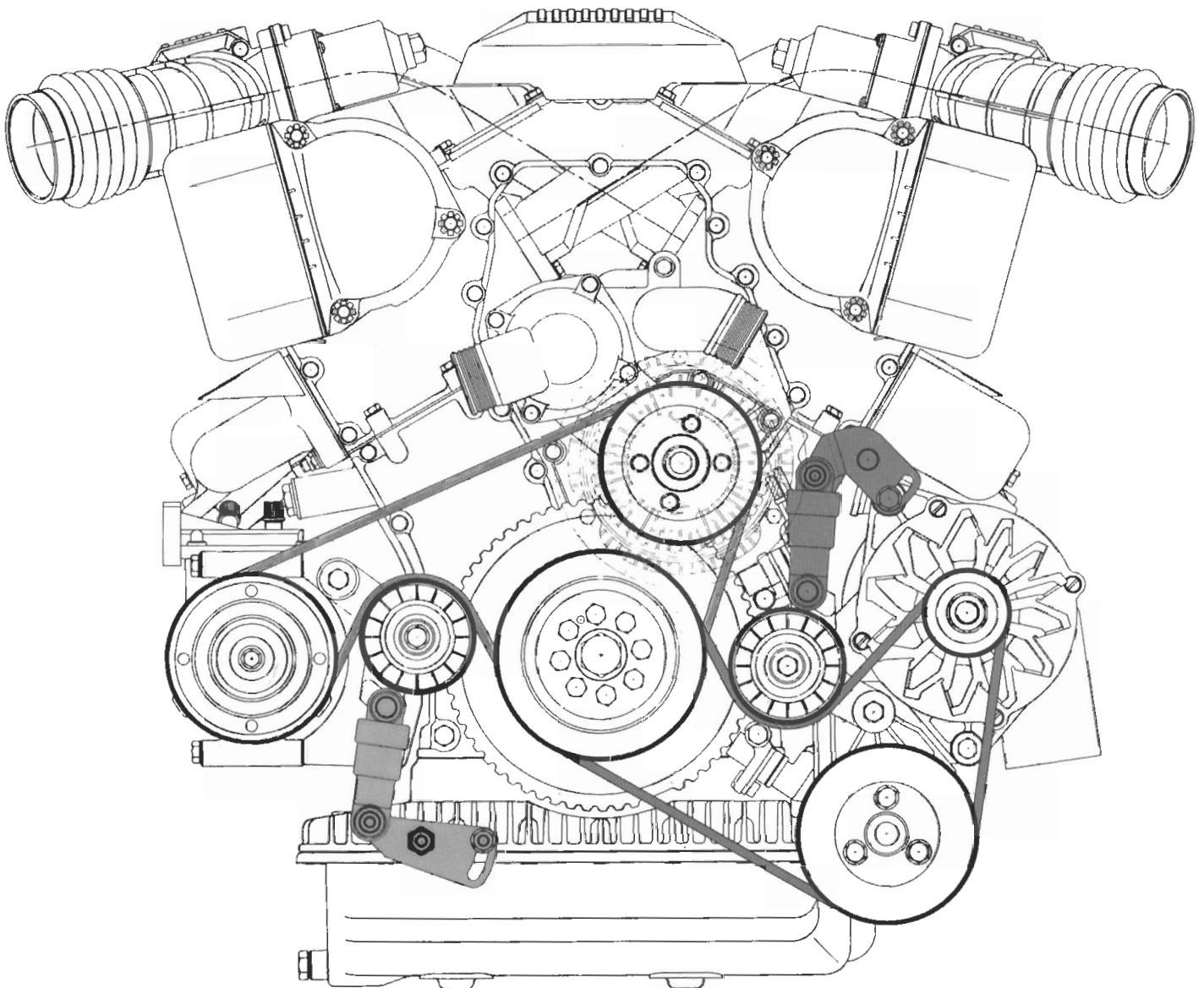


Fig. 22  
Arrangement and Drive of Auxiliary  
Equipment on V-12 Engine



Ribbed v-belts (K-profile), also known as poly v-belts, are used for the drive of this equipment.

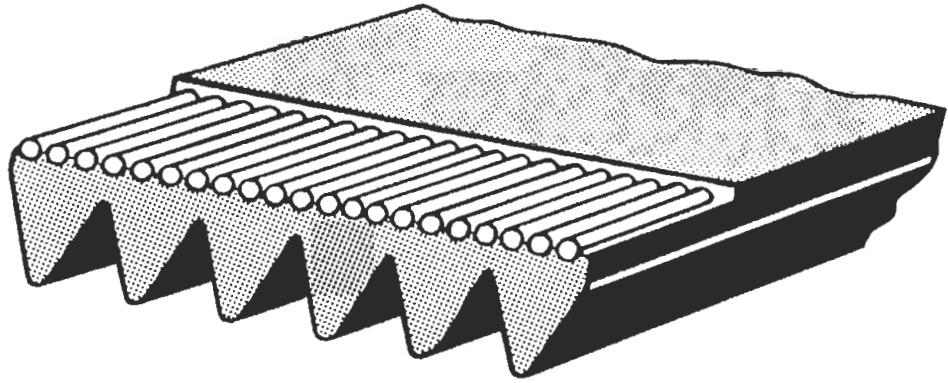


Fig. 23  
Cross Section View of Ribbed V-belt

The angle of ribs is  $40^\circ$ .  
A ribbed v-belt is capable of driving with both the profiled surface as well as the back.

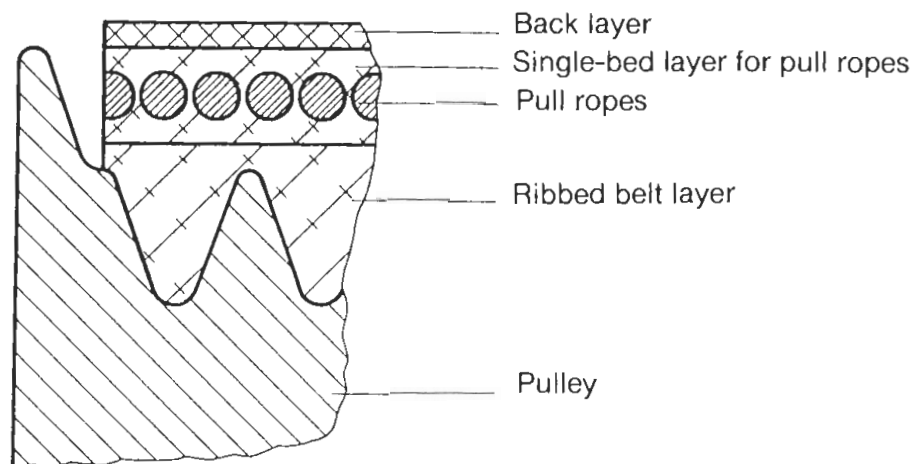


Fig. 24  
Details of Ribbed V-belt

BMW employs ribbed v-belts which have special advantages.

- Almost no settling of dirt on them, water flows off easily.
- Pulling tension in tips of ribs is low, when the belt is bent over the back.
- The profiled surface of a belt can run on a smooth pulley or roller.
- The belt wrap angle can be very small, so that it is possible to select a good drive ratio.

Both belts are tightened with tensioning rollers. Two hydraulic oil pressure dampers guarantee correct preload. The entire auxiliary equipment drive system does not require servicing.

# Air Conditioner Compressor Drive

The drive for the air conditioner compressor is equipped with an electronic overload protector. This protection system will cause immediate switching off of the air conditioner compressor in case of a difference in speed between the compressor and engine; the magnetic clutch runs freely.

Drive of the water pump and therefore cooling of the engine are guaranteed even in case of ribbed v-belt slip.

Operation of the air conditioner is only possible after re-connection of terminal 15 in case of a possible fault. The air conditioner is not included in the diagnosis system.

- IHKA = Integrated Heater + Air Conditioner Control Unit
- M = Microprocessor (electronics)
- T<sub>D</sub> = Speed signal (engine)
- SG = Control unit

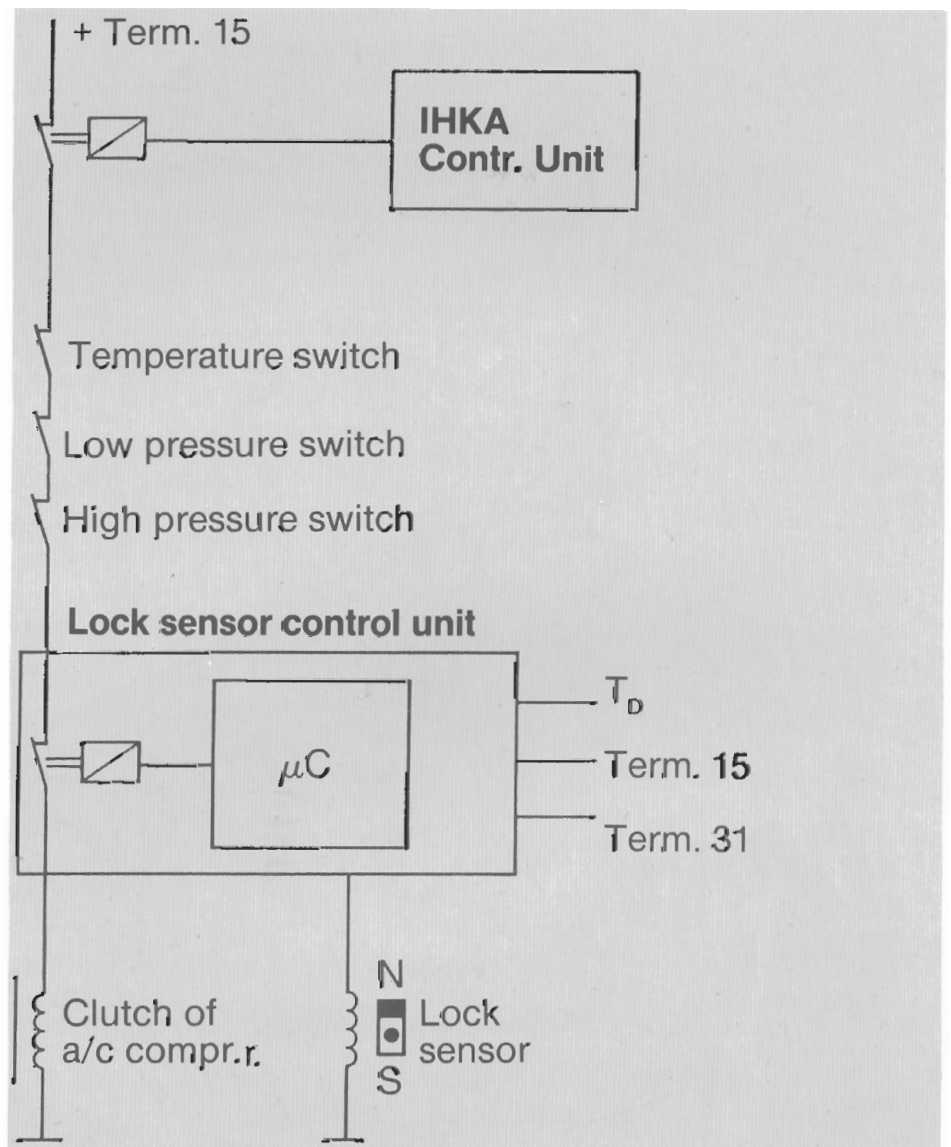


Fig. 25  
Control Block Diagram of  
A/C Compressor with Lock Sensor

## 5.2 Cooling System

Coolant flows through both cylinder heads almost symmetrically. The volume of coolant is 14 litres.

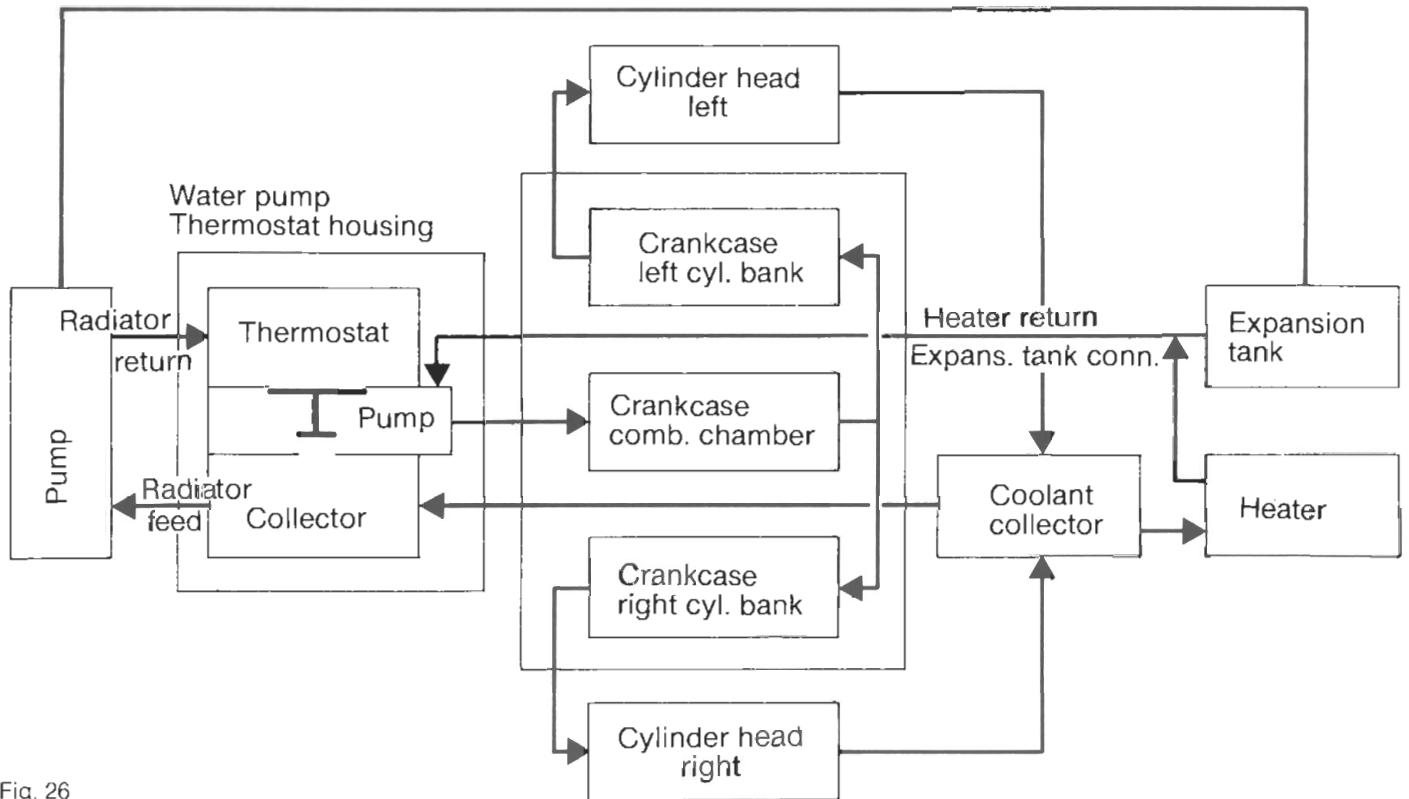


Fig. 26  
V-12 Engine Coolant Circuit

The water pump with integral body is installed in the timing chain case.

This measure considerably reduces the installed length of the engine, since coolant feed corresponds with the v-angle of the crankcase.

The thermostat opens with a coolant temperature of 80° C and is integrated in the water pump body.

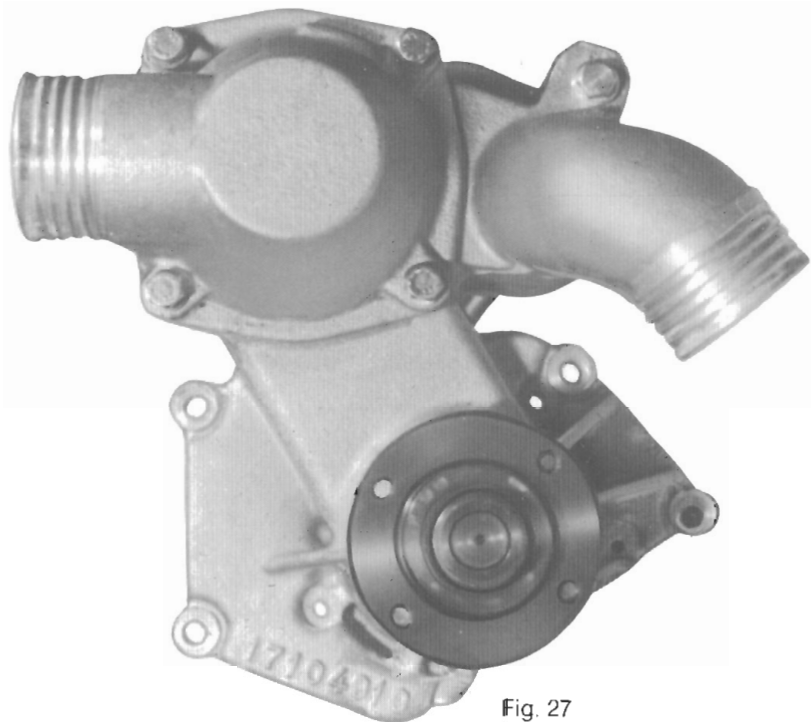
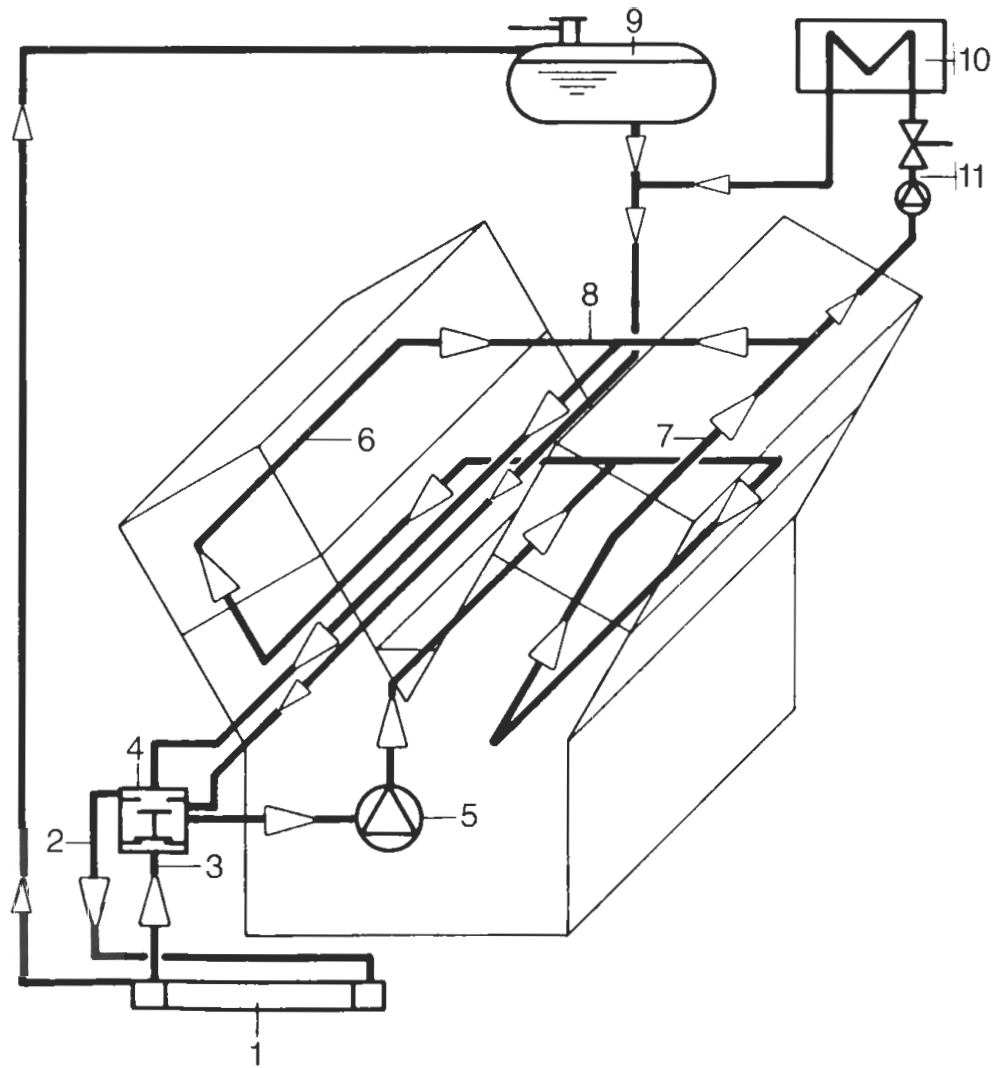


Fig. 27  
Water Pump in V-12 Engine

Fig. 28  
Coolant Circuit of V-12 Engine

- 1 Radiator
- 2 Return
- 3 Feed
- 4 Thermostat
- 5 Water pump
- 6 Right cylinder head flow
- 7 Left cylinder head flow
- 8 Connecting pipe + return
- 9 Expansion tank
- 10 Heater cooler
- 11 Extra pump with timing valve (country version)



Electric preheating of the coolant can also be applied. It is mounted in the Vee of the engine block. This heater can be supplied with 220 volts from a socket underneath the licence plate holder.

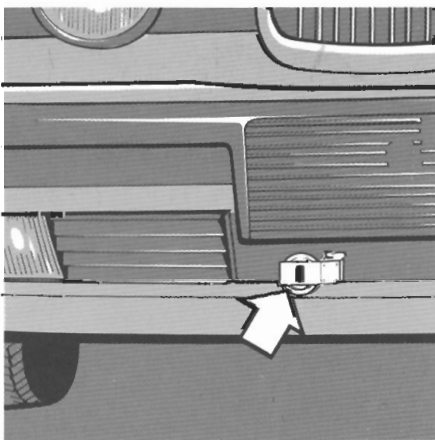


Fig. 29  
Coolant Heater Connection

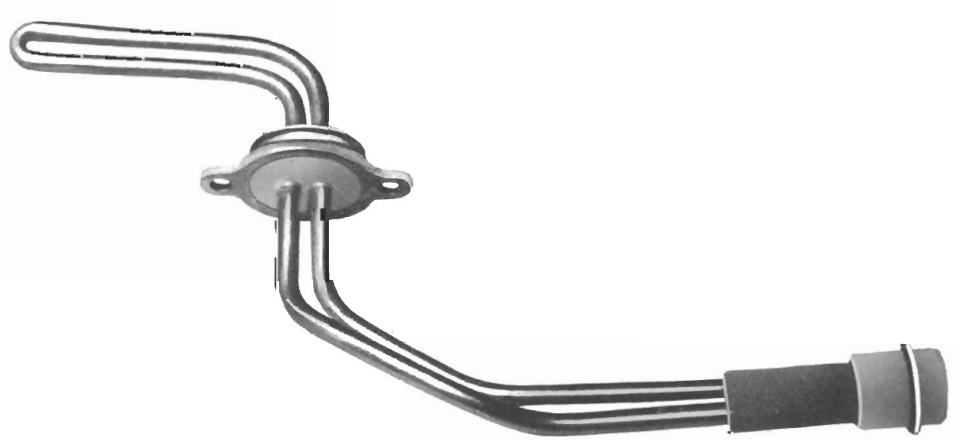


Fig. 30  
Heater for Coolant

# Fan Clutch

The fan clutch is mounted on the water pump and is speed-and temperature-controlled

- Temperature dependent switching of clutch:  
ON at 95° C  
OFF at 60° C
- Speed dependent: 2100 ± 100 rpm  
500 ± 100 rpm

There are 11 **rotor** blades with a diameter of 460 mm.

Operation of the fan clutch is described in BMW Technik 11 03 81 (1026).

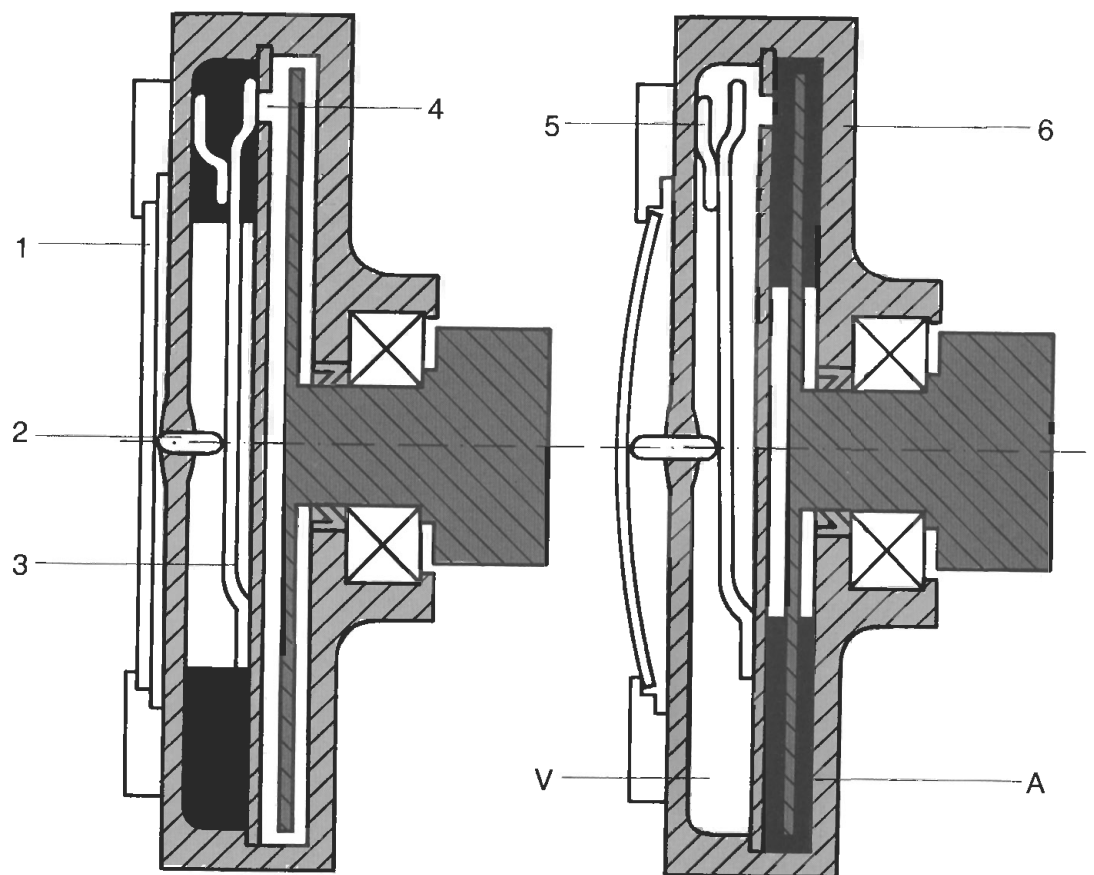


Fig. 31  
Fan Clutch Section View

- 1 Bimetal
- 2 Switching pin
- 3 Switching valve
- 4 Valve bore of intermediate plate
- 5 2nd bimetal
- 6 Drive plate
- A Work chamber
- V Supply chamber

## 5.3 Oil Circuit

An internal gear oil pump in tandem arrangement (duo-centric pump) regulates the supply of oil.

The high pressure section of the pump delivers oil from the oil sump to the lubricating points. The second pump section draws in oil from the flat part of the oil pump and delivers it to the oil head in the sump.

In this manner there is guarantee of non-foaming oil supply even under extreme operating conditions, even for the hydraulic valve clearance compensators, and the function of the latter.

### Shop Info



### Oil Pan

Make sure of absolute conformance with pertinent instructions when installing the oil pump and adjusting the drive chain.

The **oil pan** consists of two sections.

- An aluminium oil catching section.
- A deep, sandwich sheet metal oil sump. This suppresses noise radiated by the oil pump.

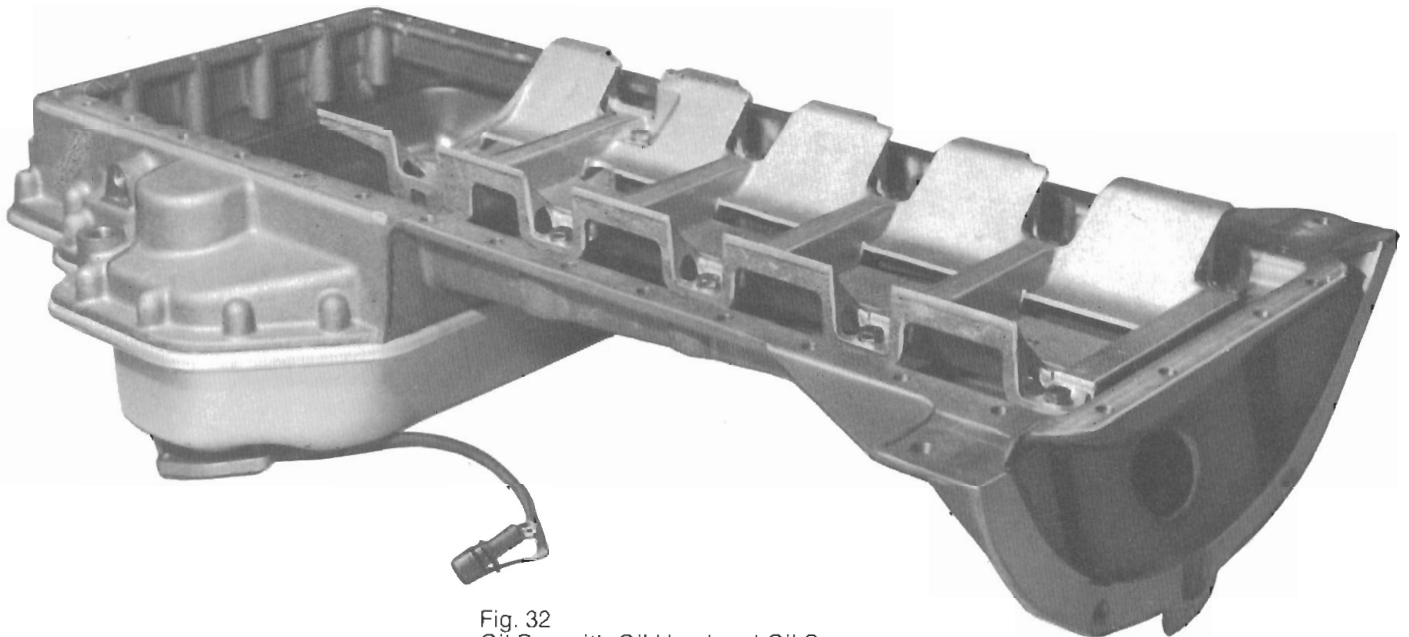


Fig. 32  
Oil Pan with Oil Head and Oil Sump

An oil catching grid, a so-called **oil head**, is installed in the oil pan. **Oil pressure** on the unfiltered oil end is **regulated** by pressure from the **filtered oil end**. Pressure remains constant on the filtered oil end even with increasing filter contamination. Oil flow is presented separately.

## Oil Filter

The **oil filter** is mounted away from the engine, in other words on the vehicle. It is easily accessible from above for servicing. Thermostatic oil cooler control is located in the bottom part of the housing. A valve opens as from a temperature of 95° C: there is flow in the cooler and oil is switched in.

The bottom section also houses a check valve. It serves to maintain an initial pressure when the engine is stopped so that oil pressure can be built up faster.

## Servicing



The oil pressure is 4 bar.

Oil volume for replacement of oil and filter is 7.5 litres.

Initial Filling:

1 litre for oil cooler

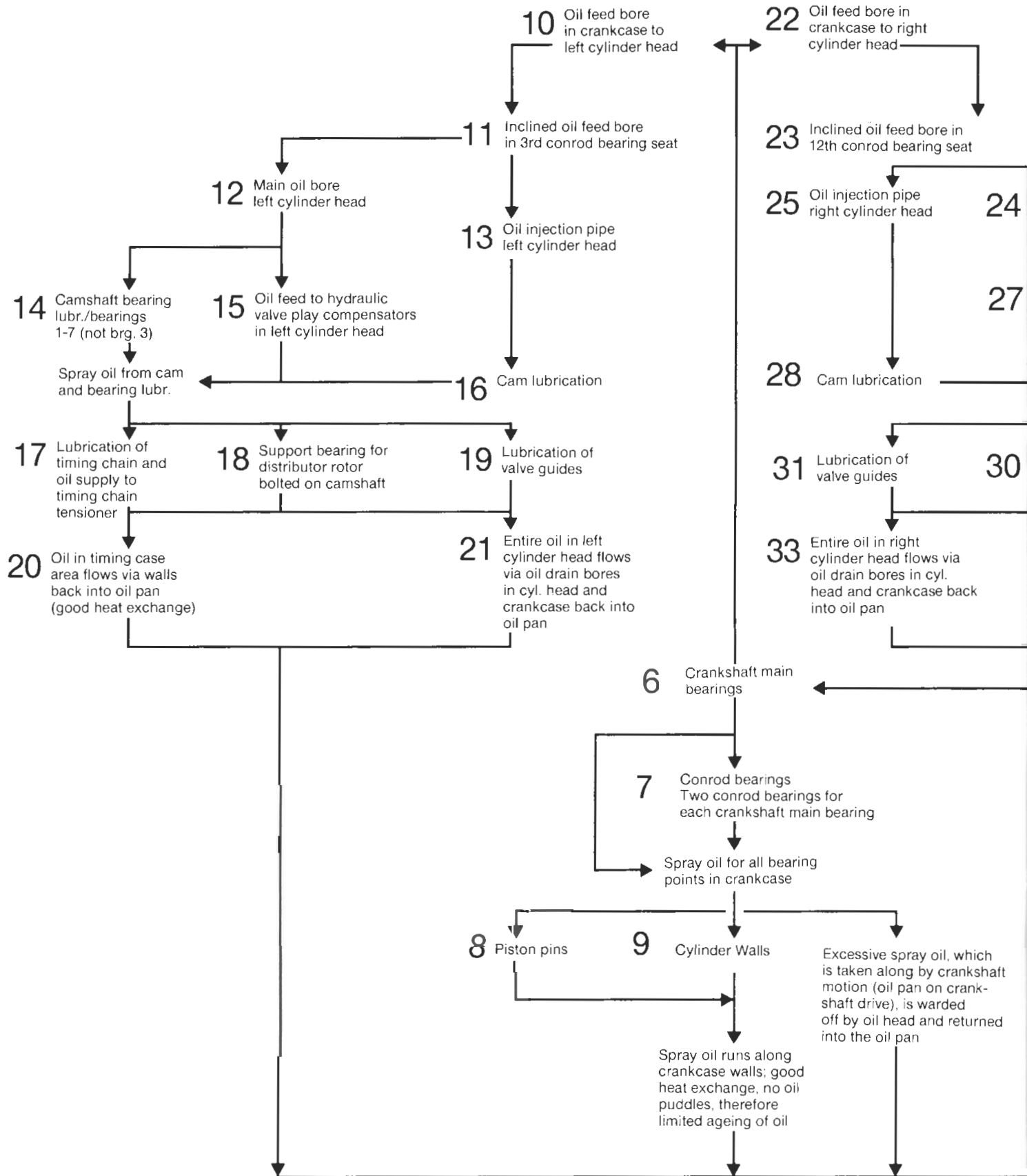
1 litre for oil filter

6.5 litres for engine

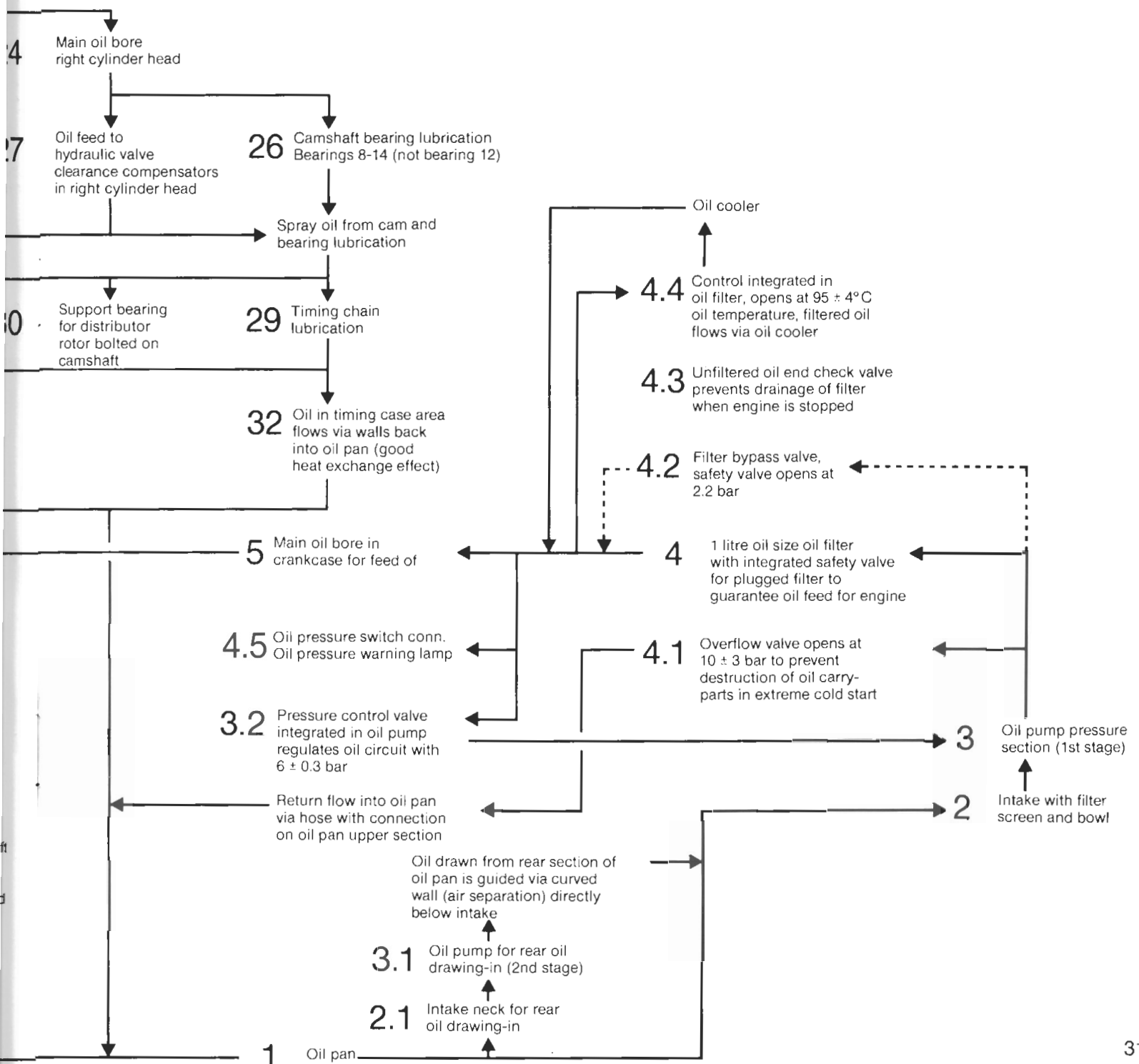


Fig. 33  
Oil Filter Housing

# M 70 Oil Circuit







## 5.4 Fuel System

The M 70 V-12 engine has two complete fuel systems working independently of each other, i.e.

- one tank holding 102 litres of gasoline,
- two intank pumps,
- separate systems of pipes for feed and return,
- separate pressure regulators with distribution pipe,
- tank ventilation via one carbon cannister and separate tank venting valves.

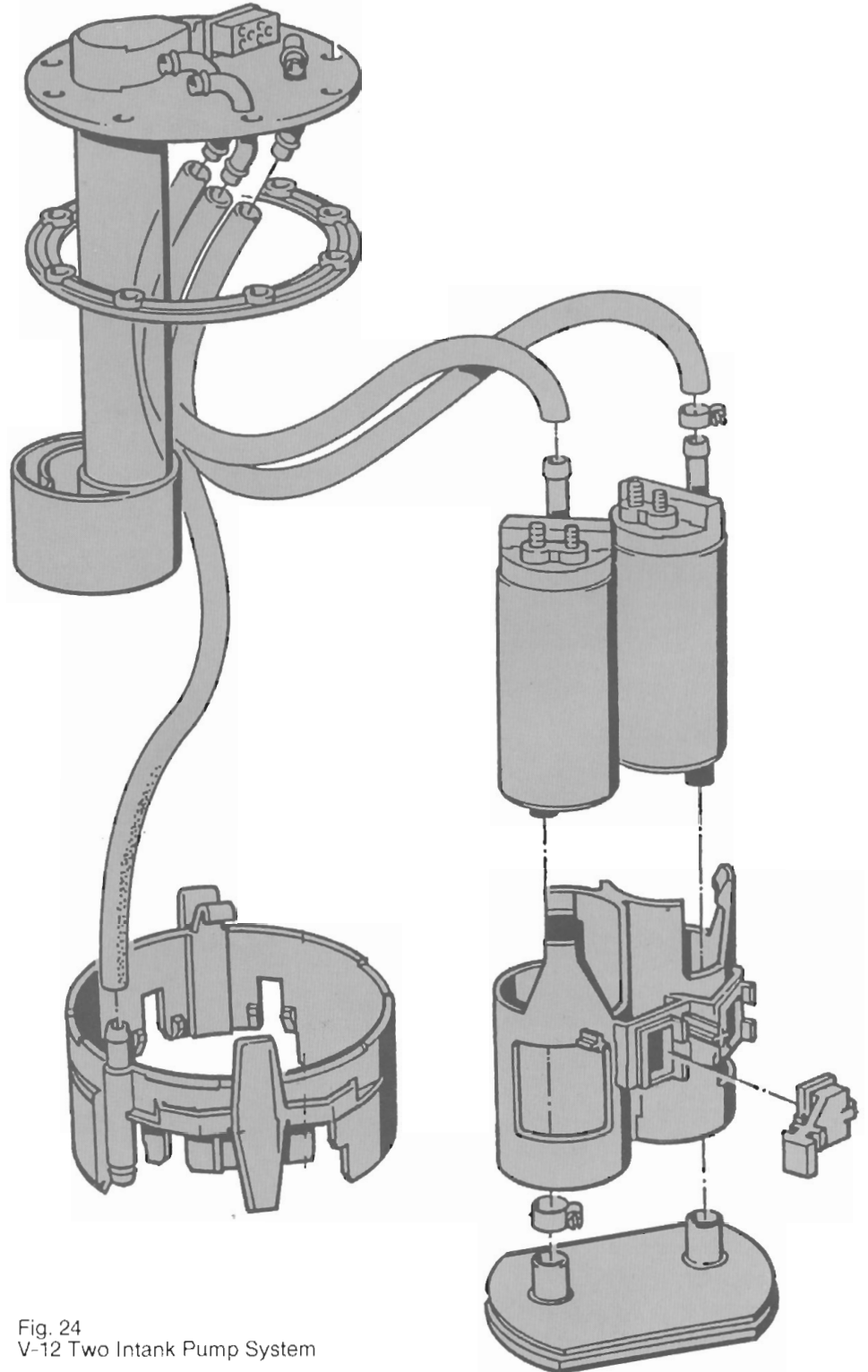


Fig. 24  
V-12 Two Intank Pump System

Gasoline flowing back in certain models is cooled by a flow-through cooler in the air conditioner feed (refrigerating end).

The fuel system works with a nominal pressure of 3.0 bar. New is the construction shape of the pressure regulator.

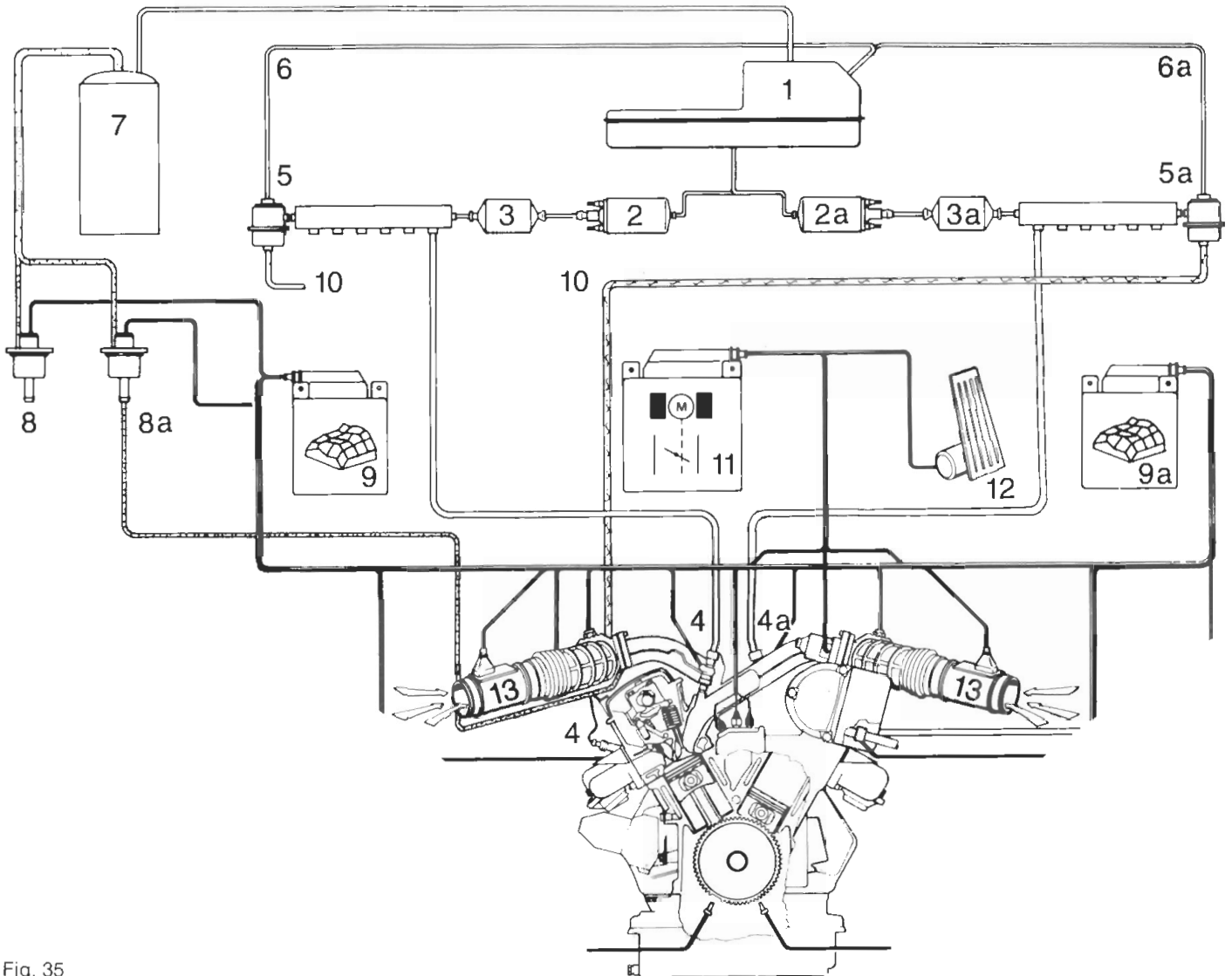


Fig. 35  
Fuel System Function Diagram

- 1 Tank
- 2 Electric fuel pump for cyl. 1-6
- 2a Electric fuel pump for cyl. 7-12
- 3 Filter for cyl. 1-6
- 3a Filter for cyl. 7-12
- 4 Fuel injectors for cyl. 1-6
- 4a Fuel injectors for cyl. 7-12
- 5 Pressure regulator for cyl. 1-6
- 5a Pressure regulator for cyl. 7-12
- 6 Return flow pipes for cyl. 1-6
- 6a Return flow pipes for cyl. 7-12
- 7 Carbon canister
- 8 Tank venting valve for cyl. 1-6
- 8a Tank venting valve for cyl. 7-12
- 9 Motronic control unit for cyl. 1-6
- 9a Motronic control unit for cyl. 7-12
- 10 Vacuum hose for pressure regulator
- 11 Engine power regulating control unit (E.M.L.)
- 12 Accelerator pedal sender
- 13 Air flow sensors

## 5.5 Air Guide

Intake air is also guided separately, since both banks of cylinders are regulated independently of each other.

Both **air cleaners** in plastic with intake necks are designed for as little as possible flow resistance. The results are a low noise level and limited corrosion.

The **throttle valves\*** are operated by engine power regulation (EML) via electric drive motors.

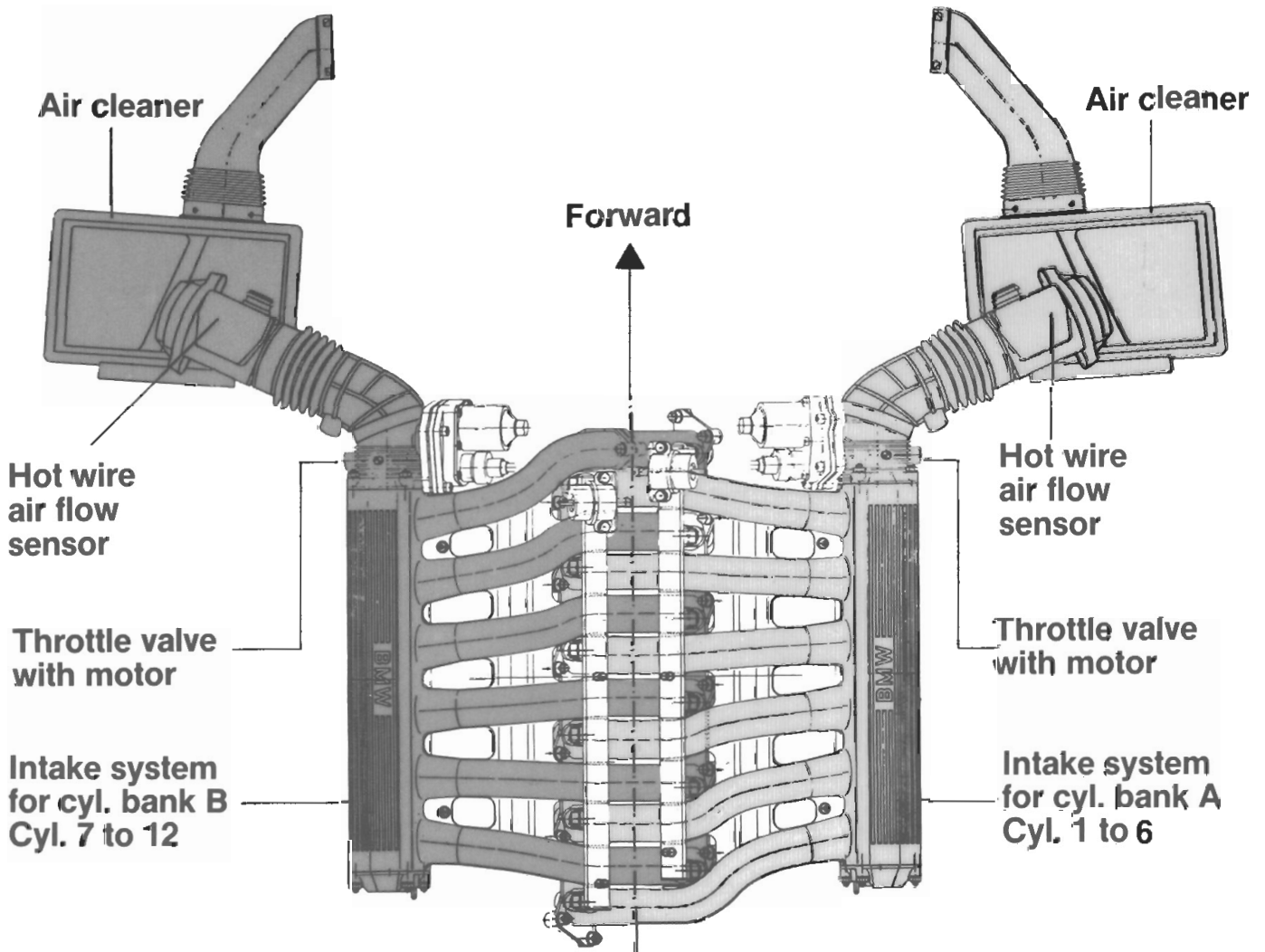


Fig. 36  
Air Guide on V-12 Engine

\*Also refer to SIP Motronic 1.1 to 1.3 or EML/ASC brochure

Long intake pipes permit favourable engine torque in medium speed ranges. Consequently intake pipes are routed via both fuel injector pipes.

Intake pipes are each suspended in uncoupled manner on the flange for the cylinder head via elastic elements. They also bear elastically on the valve cover.

This measure has two results.

- Acoustic properties of the engine are influenced positively.
- Reduced amount of load on parts attached to the intake system through oscillation.

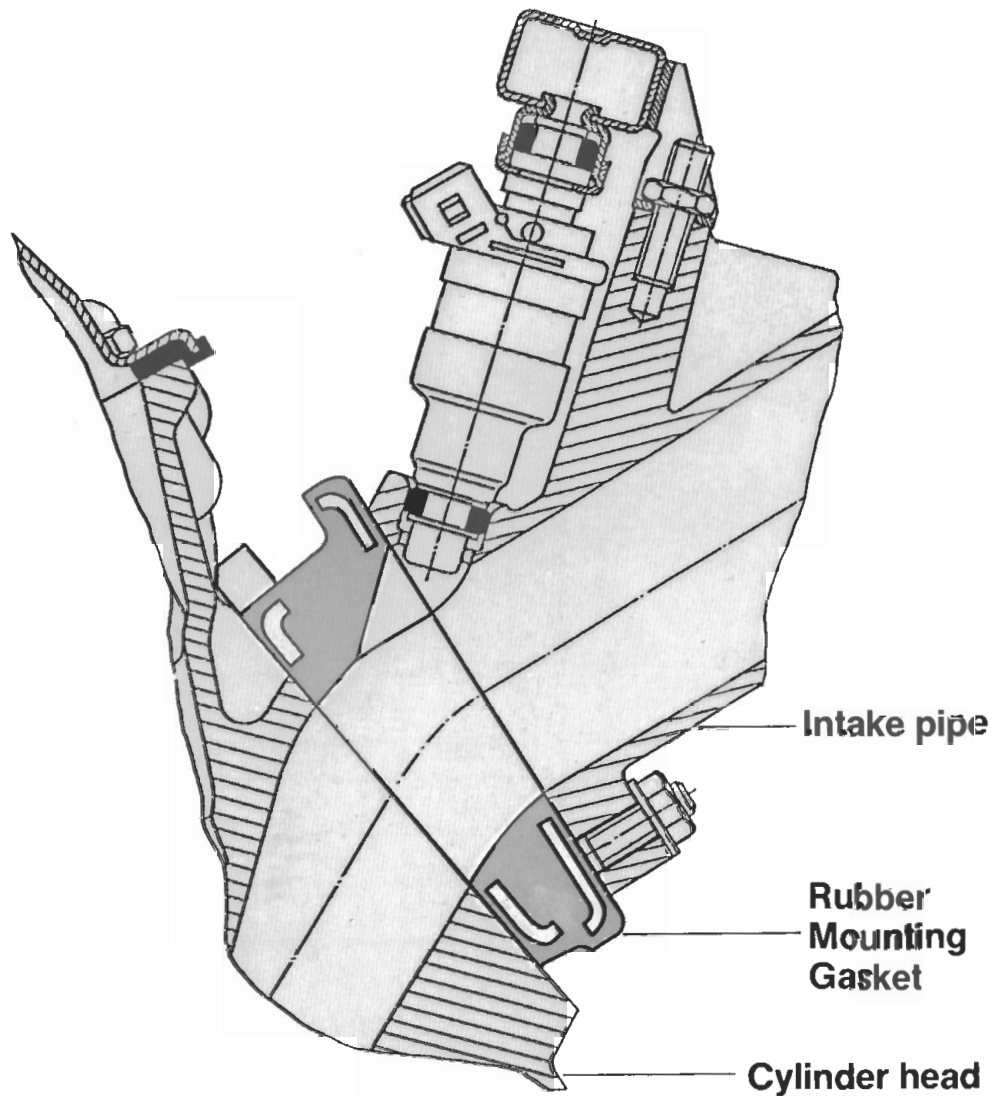


Fig. 37  
Rubber Gasket on Intake Pipe on V-12 Engine

# Hot Wire Air Flow Meter

BMW introduces a new element in the air guide system with the **hot wire air flow meter**.

The **hot wire air flow meter** replaces the plate-type air flow sensor. Its advantages are the very low flow resistance, omission of moving parts and actual amount of air taken in depending on altitude, air density and air humidity.

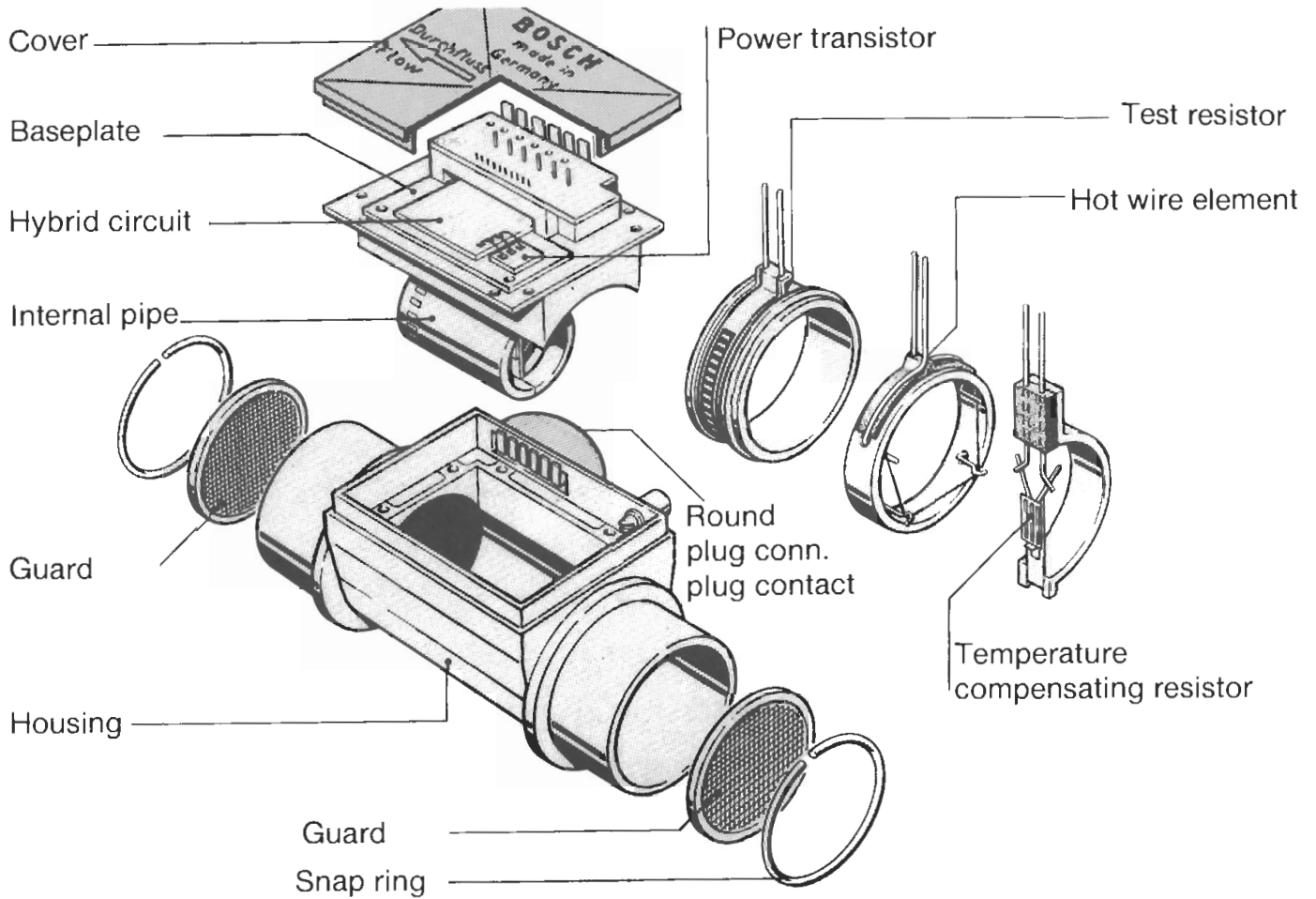


Fig. 38  
Details of Hot Wire Air Flow Meter

Both **hot wire air flow meter** have the task of determining the precise air flow rate.

The internal pipe contains the following parts for this purpose.

- Hot wire (platinum wire)
- Testing resistor
- Compensating resistor

# Function

In operating status the hot wire is adjusted to a temperature of  $155^{\circ}\text{C}$  higher than the intake air temperature by a control circuit in the air flow sensor. The control circuit works on the principle of a Wheatstone\* measuring bridge. The hot wire cools faster, the greater the air flow rate. Heating current is delivered in order to correct the balancing.

In so doing the heating current flows via a testing resistor. Voltage drop or current rise is direct measurement of the air flow rate and is processed in a pertinent control unit as information.

A compensating resistor registers fluctuations in intake air temperature.

Crankcase breathing is introduced direct in the intake manifold to protect the hot wires against oil mist and condensation.

The current circuit in the hot wire air flow sensor adjusts itself after stopping the engine — the hot wire is heated briefly to a temperature of  $1000^{\circ}\text{C}$ ; deposits are burnt away.

Certain requirements are necessary for burning-off.

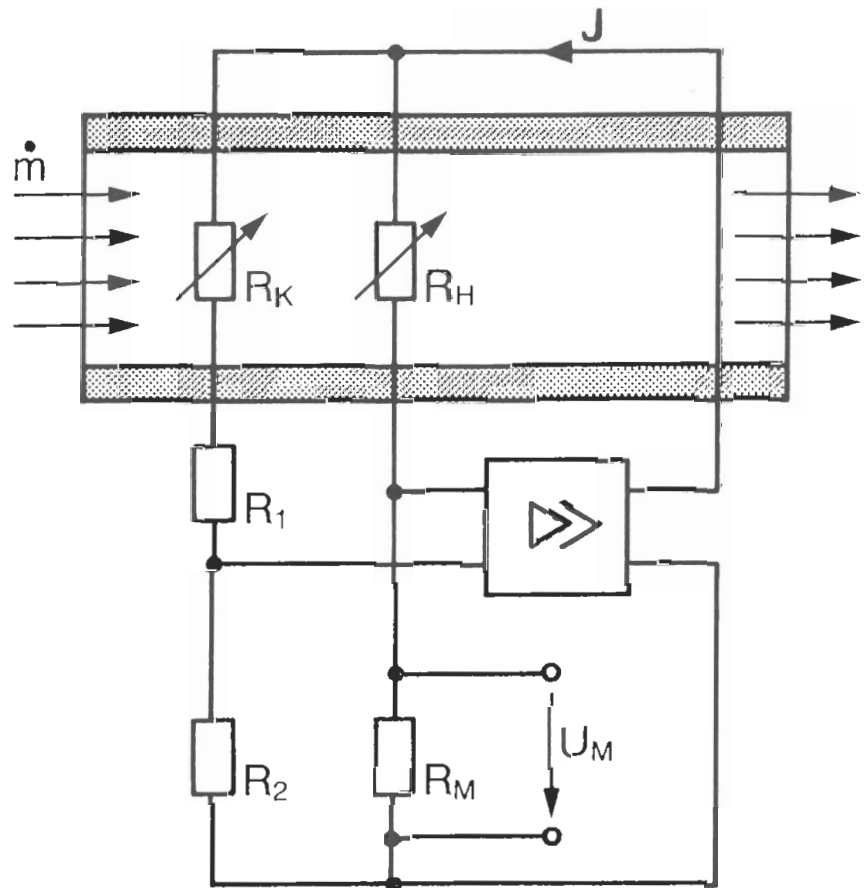


Fig. 39  
Electric Function (Hot Wire Sensor)

$R_K$  = Temperature compensating resistor

$R_H$  = Hot wire resistor

$R_M$  = Measuring resistor

$U_M$  = Measuring voltage for determination of injection time

$R_1$  = Voltage divider with  $R_2$

$R_2$  = Voltage divider with  $R_1$

$M$  = Air flow rate

$J$  = Current

**Note:**

Also refer to Motronic brochure 1.1. to 1.3 (published soon)

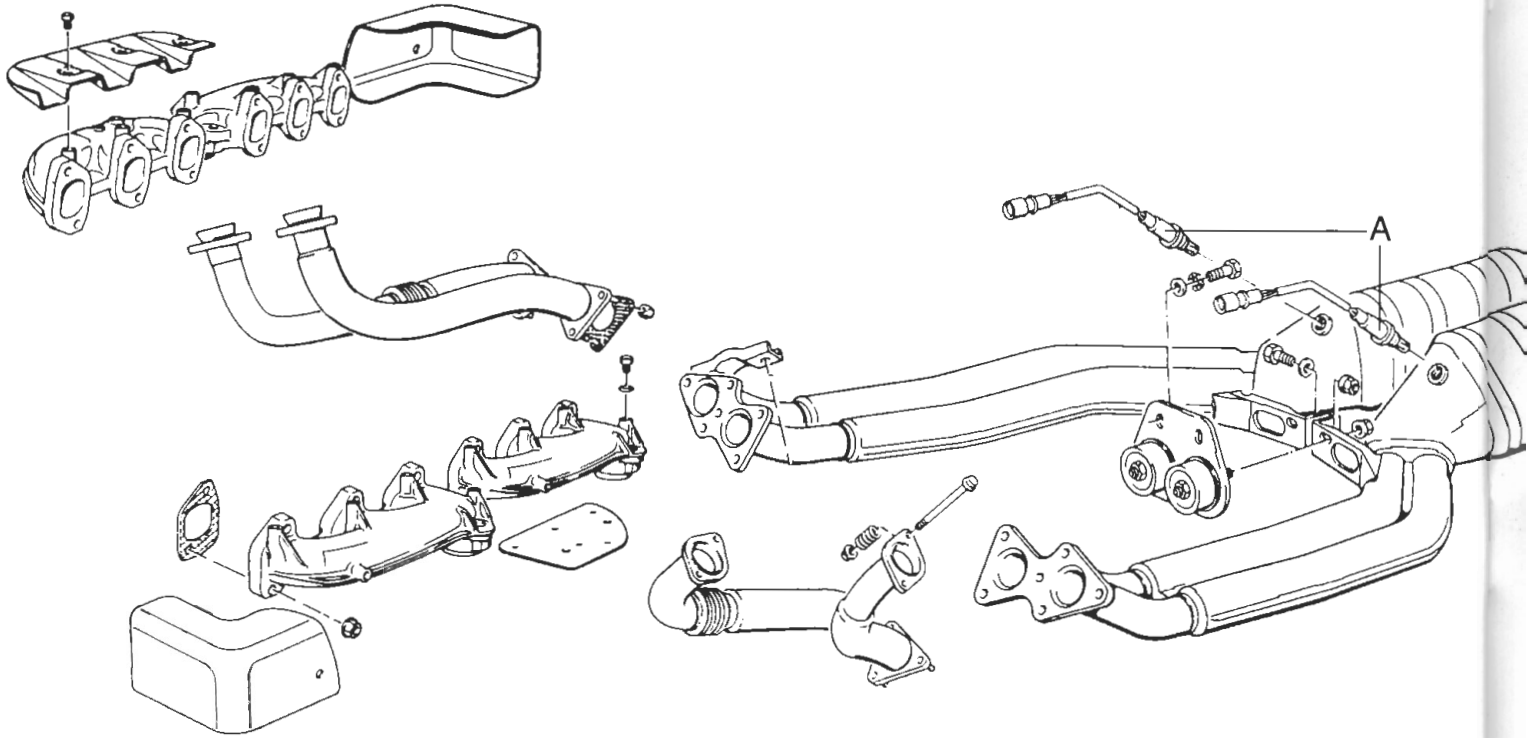
\*Wheatstone = British physicist from 1802 to 1875.

## 5.6 Exhaust

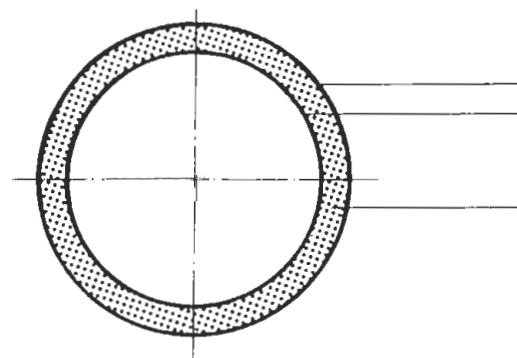
The exhaust system is a doubled designed: two-channel system and applied to each bank of cylinders.

The system is made of stainless steel.

The pipe diameter is 63 mm. This guarantees high efficiency and low flow resistance.



Both catalytic converters are mounted close to the engine. The front exhaust pipes are made of two sheet metal layers to avoid thermal loss of the exhaust gas. There is insulation between both layers.



2 sheet metal layers

Insulation

Fig. 41  
Exhaust Pipe Section Drawing



## Manifolds

The V-12 engine has four manifold parts. Three cylinders are connected on each manifold.  
The eight exhaust pipes are mounted on the exhaust with four spring-loaded, ball-shaped flanges.  
This guarantees perfect sealing throughout the service life.

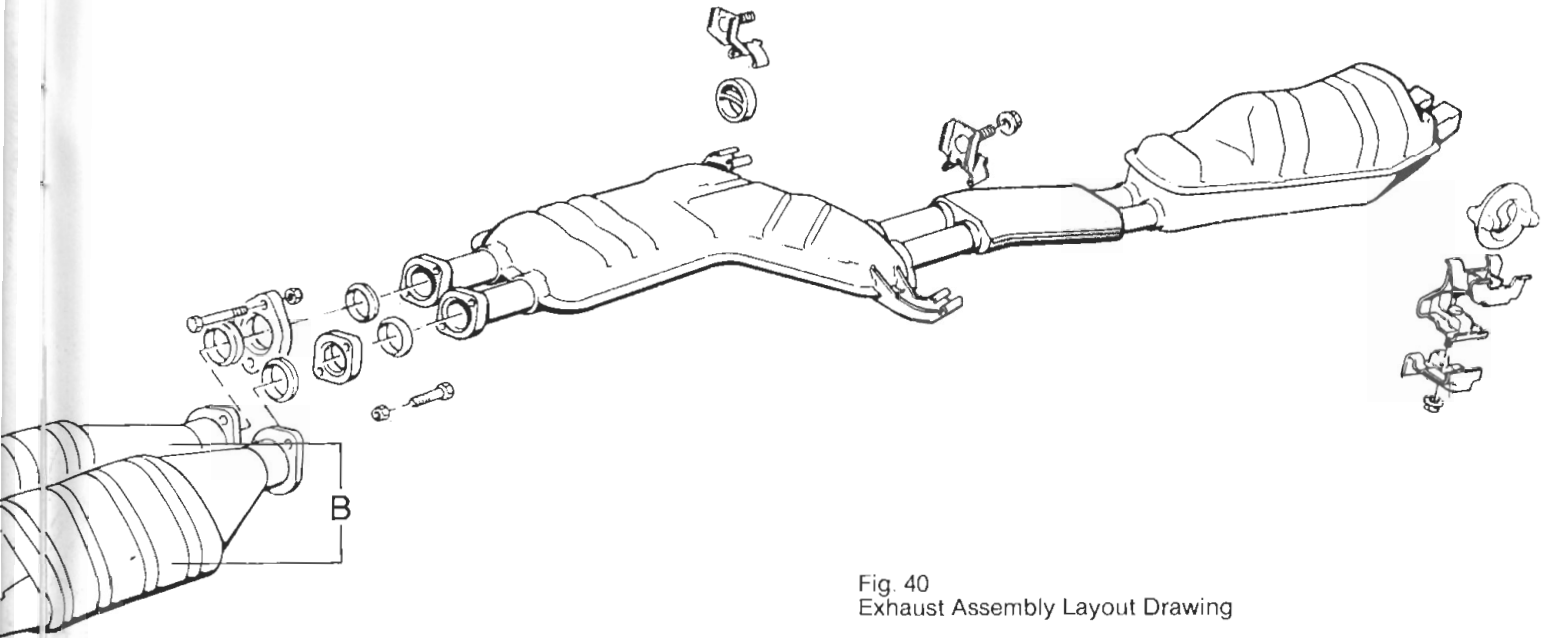


Fig. 40  
Exhaust Assembly Layout Drawing

A Oxygen sensors  
B Catalytic converters

## Catalytic Converters and Oxygen Sensors

Catalytic converters have even higher performance due to a new coating of the monoliths.  
It was possible to drop the starting temperature by about 70° C, so that it is now approx. 280° C.

New catalytic converters are adapted to the displacement, power output and air flow rate. All in all they are larger in cross section size. This keeps the exhaust backpressure low. Inside and outside noise level behaviour are improved, since the catalytic converters also serve as primary mufflers.

Catalytic converters are full load proof.

Oxygen sensors are mounted on the inlet of each of both catalytic converters.

### Note:

Cars with catalytic converters can be operated on either unleaded regular grade or unleaded premium grade gasoline.

# 6. Car Electrical System and Electronics

## 6.1 Alternator, Battery, Starter, Ignition

The alternator has a power output of 14 V/115 A or 140 A. It is cooled with fresh air taken from the radiator grill.

The higher power output results from the tighter stator winding. The diode plate was modified and fitted with eight additional diodes.

Drive is off a multiple-belt pulley.

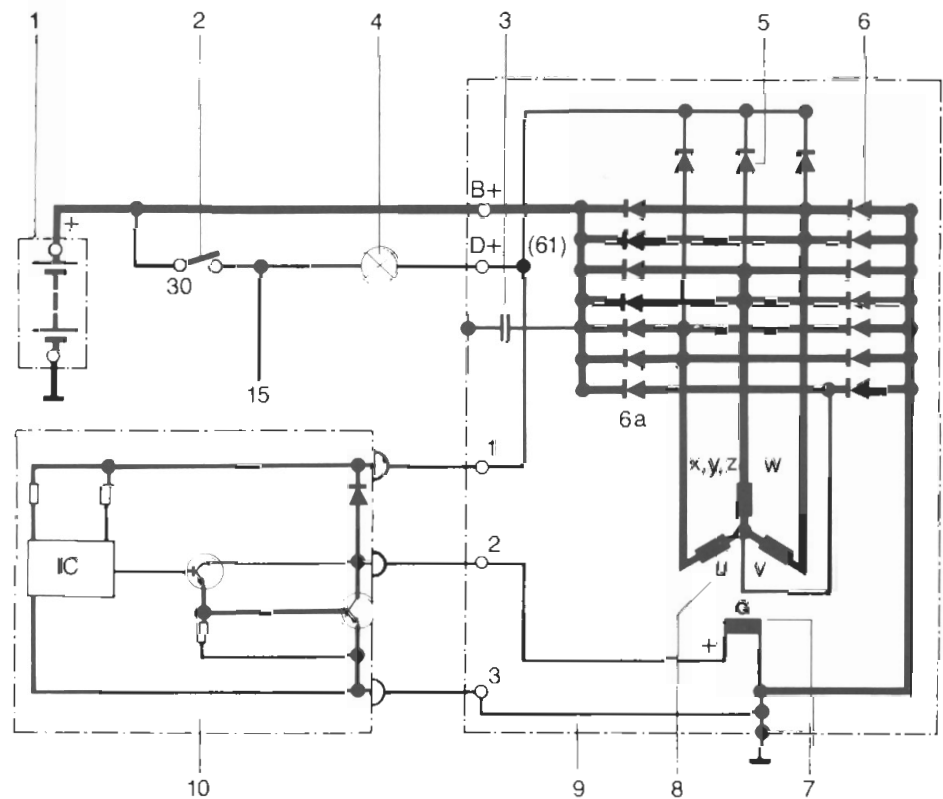


Fig. 42  
Principal Wiring Diagram  
of 115/140 A Alternator

- 1 Battery
- 2 Ignition lock
- 3 Capacitor
- 4 Charge indicator lamp
- 5 Exciter diodes
- 6 Negative diodes
- 6a Positive diodes
- 7 Exciter windings
- 8 Stator windings
- 9 Alternator switch block
- 10 Regulator switch block

The battery is designed for 12 V/84 Ah and, as for all E 32 cars, located underneath the rear seat.

## Starter

The starter develops 2.2 kW power and is equipped with an intermediate transmission. It guarantees good starting at any temperature and in spite of mechanical resistance.

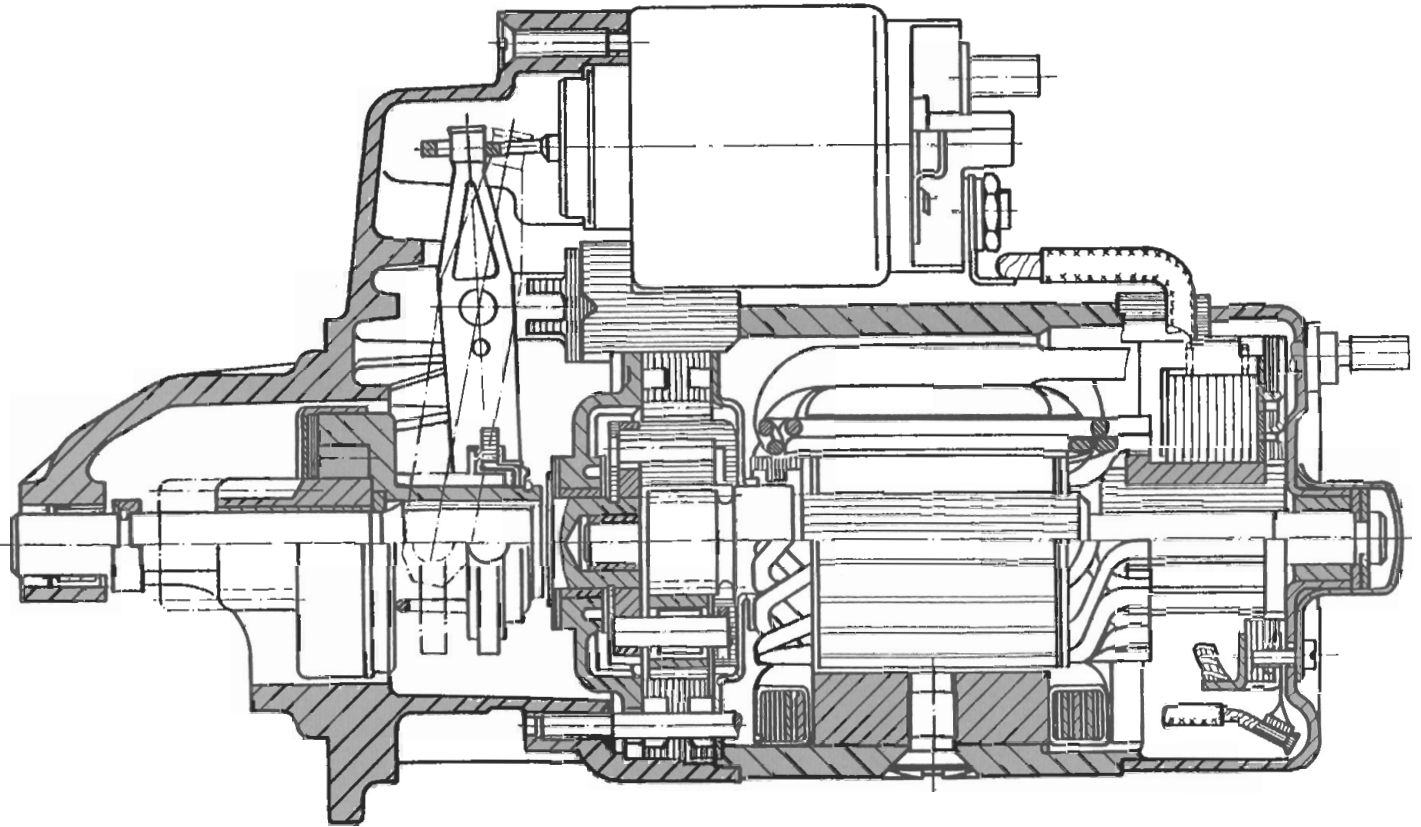


Fig. 43  
Starter Motor Section Drawing

## Ignition

The **spark plug** has 14 mm threads and a heat range of W 145 R. It is positioned in the combustion chamber in such a manner that short flame travel with high compression can be realized.

The spark plug connector is made of ceramics.

Leads and connectors themselves are of the proven 30 kV System.

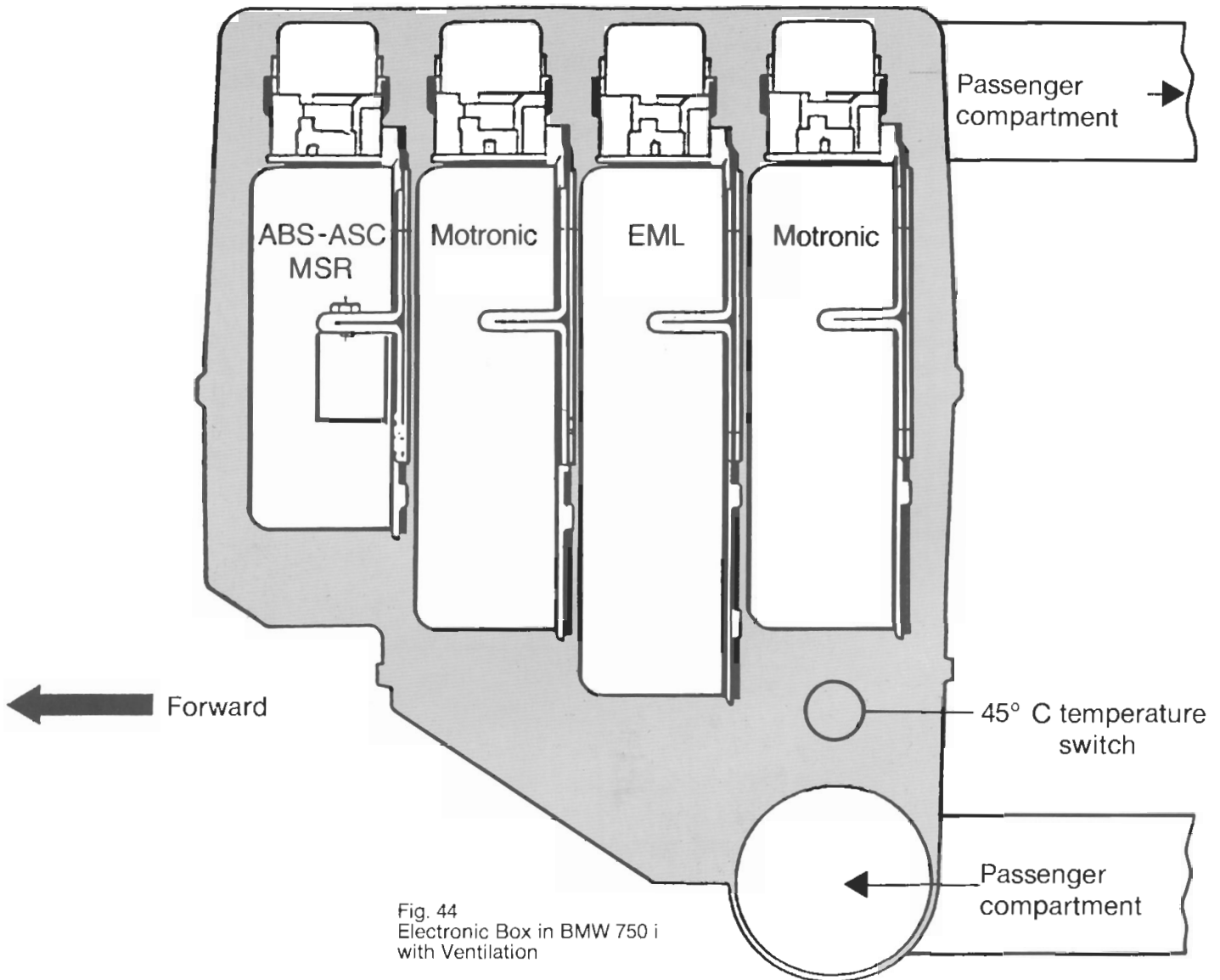
The V-12 engine also has two Motronic ignition systems.

## 6.2 Electronic Box

Control units are located in a central electronic box for protection against environmental conditions.

An appropriate air duct provides sufficient cooling. All control units of the M 70 V-12 engine are fitted with 55 pin plugs.

There is additional cooling from a temperature controlled blower in cars for several countries.



## Relays

Relays are located in a relay box in the engine compartment on the right-hand side.

- Power supply of Motronic/EML 2 relays
- Electric fuel pump 2 relays
- Oxygen sensors 1 relay for both

## 6.3 Engine Control Management

New Motronic is introduced with the M 70 V-12 engine. Functions of Motronic 1.1 are adapted and their contents extended.

Completely new is the drive control with a system of interconnected functions.

The composite system\* for the M 70 V-12 engine control comprises the following systems.

### Motronic 1.2

- Independent Motronic for each bank of cylinders; consequently two independent control units for injection, ignition and various functions. Air mass measuring system is used instead of an air volume measuring system. This Motronic is therefore known as Motronic 1.2

### EML

- Electronic Power Regulation (EML) has priority over and is connected with the two Motronic systems.

### ASC MSR

- Both Motronic systems and EML are connected with Automatic Stability Control (ASC) and integrated Engine Drag Torque Regulation (MSR) (optional extra equipment).
- 4 HP 24 Independent Electronic Transmission Control (AEGS).

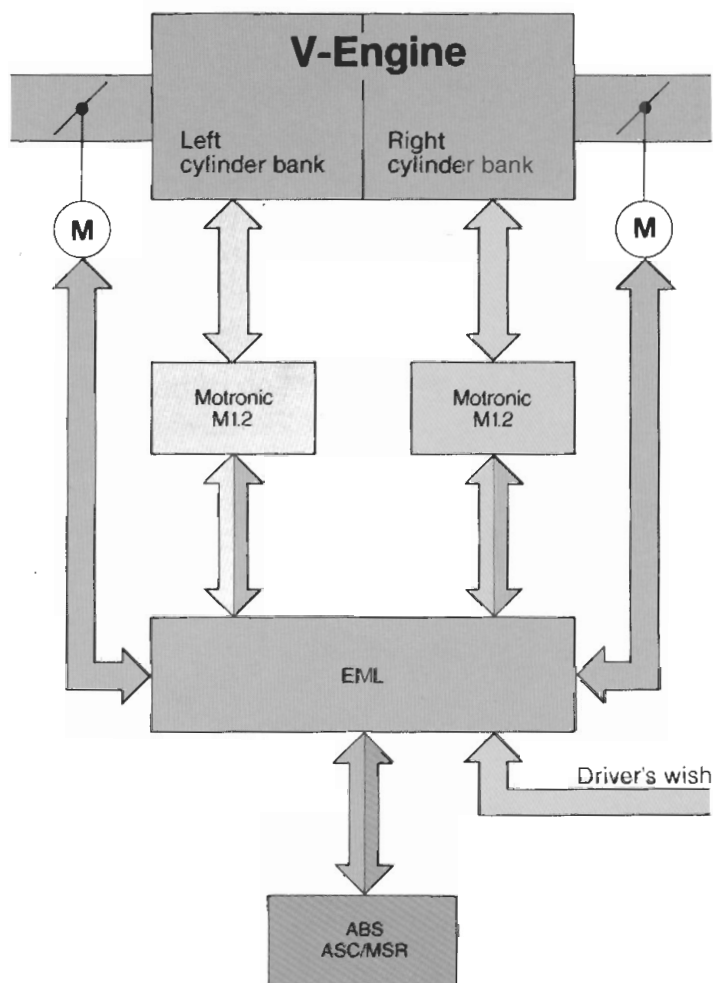


Fig. 45  
M 70 Engine Control Composite System

\*also refer to SIP films

## **6.3/1 Motronic 1.2 Functions**

Motronic 1.2 for the M 70 engine is modified or supplemented as follows in regards to components.

- Hot wire air mass sensors instead of flow sensors.
- Omission of idle speed control.

Functions included in Motronic 1.1 are optimised in Motronic 1.2 and adapted to the requirements of the M 70 V-12 engine.

Design and function of the air flow sensors have already been described on page 36.

## **6.3/2 EML Functions**

The old method of operating throttle valves mechanically through load cycles via the accelerator pedal, transmitting/operating linkage or cable is omitted in M 70 V-12 engines. They are replaced by electronic controls.

EML electronically regulates or controls:

- the operation of both throttle valve motors, synchronization of both throttle valve motors, in conjunction with idle speed and charge regulation, and cruise control speed (tempomat).

Load cycle is reported to the EML control unit by a position signal while operating the accelerator pedal value sender. The control unit opens or closes the throttle valves accordingly with this information.

EML guarantees in particular synchronization of both throttle valves. This is accomplished by increasing the air flow rate for so long, until both Motronics report the same injection signal ( $t_i$ ) to the EML control unit.

EML limits the top road speed to 250 km/h depending on different information such as the  $t_i$  signal,  $t_L$  signal, EH transmission input speed and speed signal.

The speed limit cannot be manipulated.

EML also limits the top road speed with help of charge control.

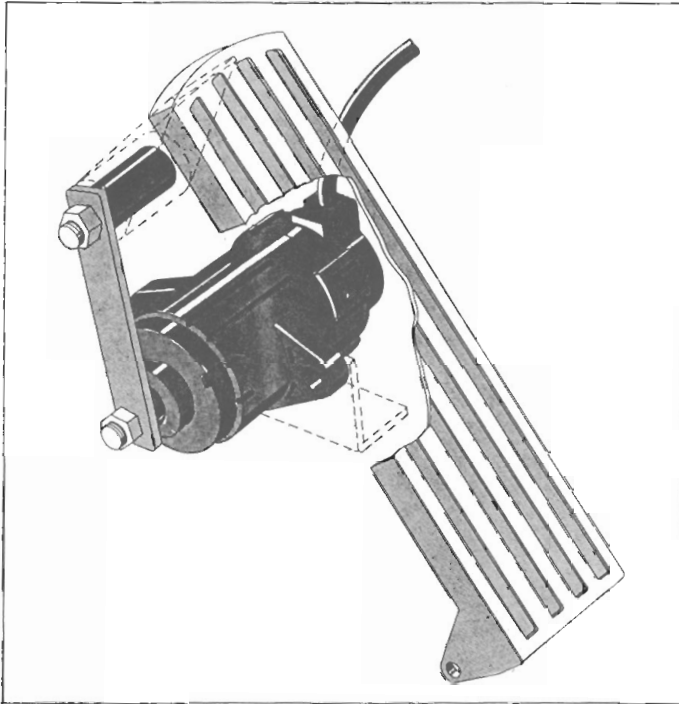


Fig. 46  
Accelerator Pedal with Pedal Value Sender

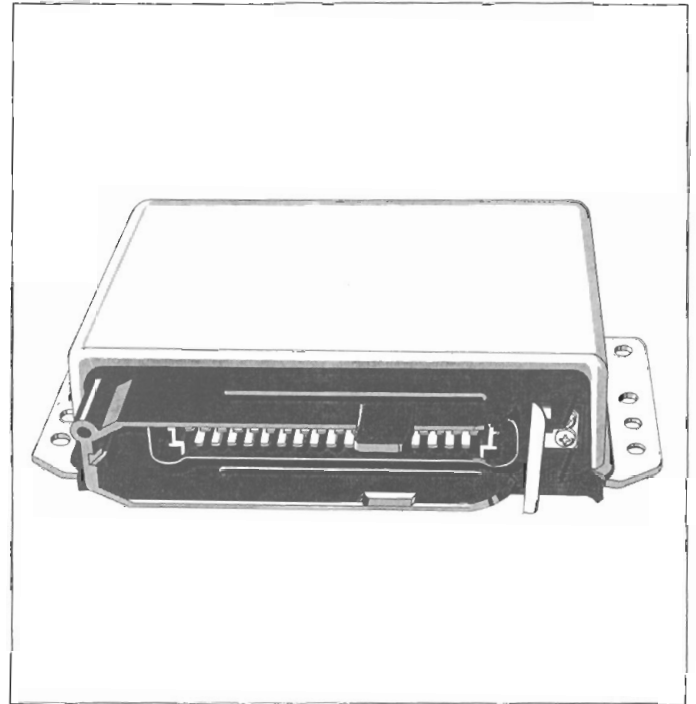


Fig. 47  
EML Control Unit (55 Pins)

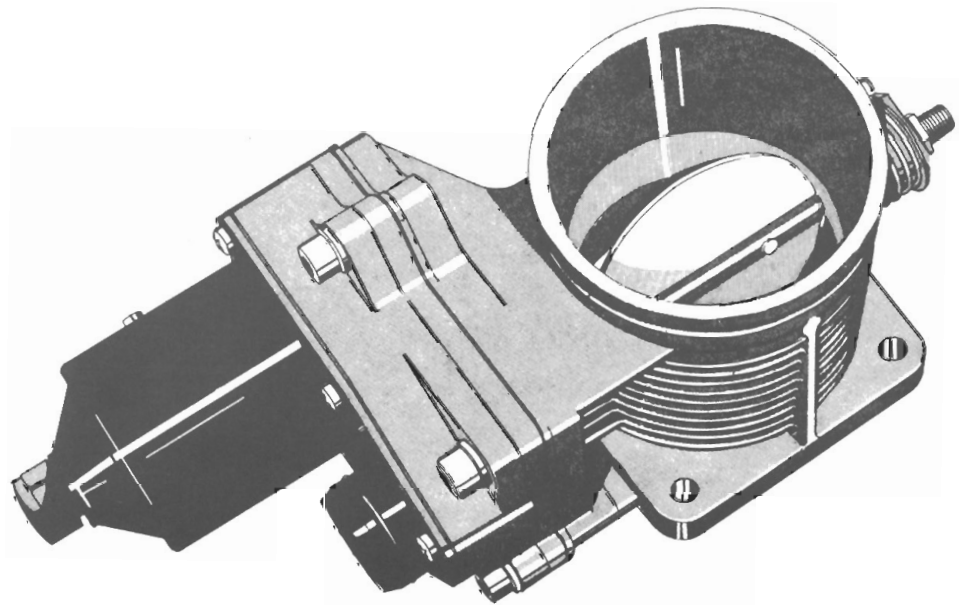


Fig. 48  
Throttle Valve Housing with Motor

## 6.3/3 ASC/ ABS/MSR Functions

If the car is equipped with Automatic Stability Control, it has influence on EML. Throttle valve motors will be operated according to driving and operating conditions via this composite system of ASC/MSR and EML Motronic I/II; also ignition will be cut out or fuel injection switched off. EML will also regulate the engine drag torque while coasting and braking.

ASC comprises the already known ABS function. When wheel slip occurs on the wheels, ASC reacts as a logic reverse of the ABS system and introduces appropriate regulation of engine torque via EML.

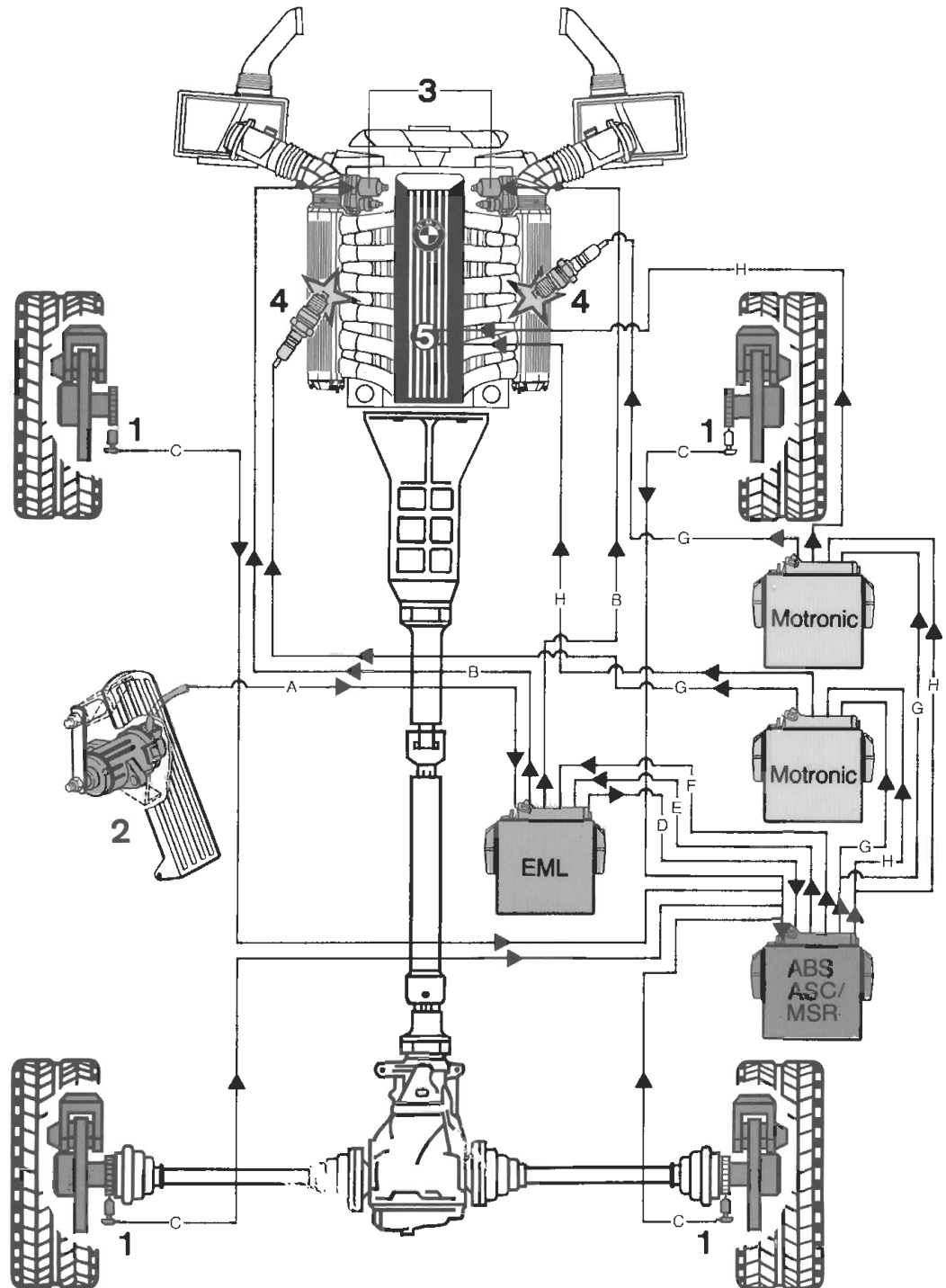
Fig. 49  
EML/ASC/MSR Function Diagram

### Components:

- 1 wheel speed sensors
- 2 Accelerator pedal with position sender
- 3 Throttle valves with electric motors
- 4 Ignition systems
- 5 Fuel injectors

### Inputs/Outputs

- A Accelerator pedal position
- B Activation of throttle valve motors
- C Wheel speed identification
- D Throttle valve allowed value
- E Throttle valves — closing
- F Throttle valves — opening
- G Via Motronic: ignition timing control
- H Via Motronic: injection rate control





## 6.4 Engine Data and Values BMW V-12 Engine

| <b>Engine Code: 5012 A</b> |  |                    |
|----------------------------|--|--------------------|
| V-angle                    | 60°  |                    |
| Displacement               | 4,988  | cm <sup>3</sup>    |
| Bore                       | 84   | mm                 |
| Stroke                     | 75   | mm                 |
| Firing order               | 1-7-5-11-3-9-6-12-2-8-4-10                                       |                    |
| Power (DIN)                | 220/300  | kW/HP              |
| at speed                   | 5200   | rpm                |
| Specific power             | 44.1   | kW/dm <sup>3</sup> |
|                            | 60.1   | HP/dm <sup>3</sup> |
| Mean piston speed          | 13.0   | m/s                |
| at rated speed             | 5200   | rpm                |
| Max. torque                | 450  | Nm                 |
| at speed                   | 4100   | rpm                |
| Max. top speed             | 6000 ± 40  | rpm                |
| Constant speed             | 5900   | rpm                |
| Idle speed                 | 700 ± 50   | rpm                |
| Compression pressure       | 10 to 12   | bar                |
| Specific torque            | 90.2   | Nm/dm <sup>3</sup> |
| Max. specific power        | 1.13   | kJ/dm <sup>3</sup> |
| Compression ratio          | 8.8 to 1   |                    |
| Fuel grade                 | Unleaded regular grade gasoline (RON 91)                         |                    |
| Engine weight              | 240  | kg                 |
| Oil volume                 | 7.5  | litres             |
| Valve diameter:            |  |                    |
| Intake valves              | 42   | mm                 |
| Exhaust valves             | 35   | mm                 |
| Fuel and ignition systems  | 2 Digital Motor Electronics M 1.2 with hot wire air flow sensors |                    |

## **6.5 Wiring Diagrams**

- Edition: July, 1987
- Subject to changes without prior notice.  
Wiring diagrams are not kept up-to-date with changes.
- Only for training purposes.

## **6.6 Tightening Torque Engine Layout**

- Not kept up-to-date with changes.
- Only for training purposes.