

Owner's Handbook

528e
535i/S
M5

*Alloy Body
Mirrors
Sand in Trunk
Map Light*

U.S. and Canadian models only

Some equipment shown in this manual will pertain only to one model.

Bayerische Motoren Werke AG Munich



In the interests of continuing technical development we reserve the right to modify designs, equipment and accessories.

Dimensions, weights and performance data quoted in this handbook are to the tolerances laid down by German Industrial Standard (DIN).

No claims based on data, statements, descriptions or illustrations from this handbook will be entertained.

Errors and omissions excepted.

As far as required for their operation the description of optional extras not listed up in this owner's manual can be looked up in the enclosed installing instruction or owner's manual.

In case of questions please contact your BMW dealer.

Please note that any discrepancies between your own car and the details given in the handbook may be due to the equipment specification offered on a particular model or the items ordered with the car.

The BMW Service Organisation will gladly advise you on subsequent equipment installation.

Any modification to the car and its equipment may result in an improper function or reduce safety and value.

© 1986 Bavarian Motor Works (BMW) AG
Munich, West Germany

Not to be reproduced wholly or in part without written permission of BMW AG Munich.

Order No. 01 47 9 699 397
1. edition 30. VIII/86
Printed in West Germany

In this owner's handbook you find important information concerning operating instructions, vehicle care, maintenance and technical details for your new BMW.

We recommend you study the Owner's Handbook before your first journey so that you become acquainted with your new car and with its various functions.

A comprehensive index will aid you in finding more detailed information on the various features and operations of your new car.

Please keep in mind that regular care and maintenance are necessary for the operational safety of the vehicle as well as to maintain its resale value.

We wish you many safe, pleasant journeys,

Sincerely
BAYERISCHE MOTOREN WERKE
Aktiengesellschaft

Energy-conscious driving:

- Fuel economy is mainly dependent on your style of driving.
- Do not warm up the engine to operating temperature at idle speed and avoid having the engine idle for long periods.
- Never drive up to maximum speed in 1st gear – use it only for starting off.
- Shift up to a higher gear as soon as conditions permit and try to drive in the higher and more economical 3rd, 4th or 5th gear.
- Avoid driving at full throttle for long periods.
- Avoid carrying unnecessary weight.
- Check tire pressures regularly.

Besides:

Energy-conscious driving reduces exhaust gas emission and noise.

Warning: Use unleaded gasoline only. Fuels containing up to and including 10 % ethanol or other oxygenates (e. g. ethers and ketones), or up to and including 3 % methanol **plus** an equivalent amount of co-solvent **only**, will not void the applicable warranties respecting defects in materials or workmanship.

However, driveability, starting and stalling problems may result from use of such fuels, especially under certain environmental conditions such as high ambient temperatures and high altitudes, and as a result, unscheduled maintenance may be required.

Some fuel suppliers sell fuels containing alcohol or other oxygenates without disclosing this information to the consumer. If starting, stalling or driveability difficulties occur, and are suspected to result from the fuel being used, it is recommended that you switch to a fuel known to contain no alcohol or other oxygenates. Check with the service station operator to determine if the fuel contains alcohol or other oxygenates.

Similar conditions may occur when fuels not having adequate detergency are used. Only use fuels advertised to have such cleansing power. If driveability problems persist, consult your Authorized BMW Dealer, who can recommend a fuel additive that will provide sufficient detergency.

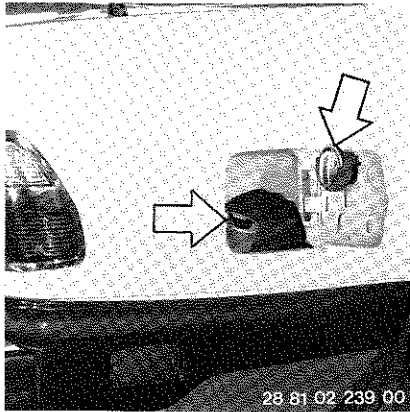

Filling of the fuel tank

Opening: Turn the fuel filler cap counterclockwise and take it off.

Closing: Turn the cap clockwise to the stop (bayonet fitting).

Fuel filler

The fuel filler neck is equipped with a leaded fuel restrictor and a check valve. The restrictor prevents the insertion of fuel filler nozzles not designed for lead free fuel.

The check valve prevents the fuel vapors from escaping from the fuel tank.

Opening of the fuel filler flap in case of a failing of the central locking system:

Press back the locking rod, accessible through the hole in the trunk lining on the right.

Items to check regularly:

- Tire pressures, front and rear, every two weeks, tire pressures, see page 78
- Engine oil level, see page 45
- Automatic transmission fluid level, see page 47
- battery acid level, filling up, see page 49
- coolant level, see page 48
- brake fluid level, see page 48
- light system, see page 55
- Windshield washer fluid level, see page 49.

Required fuel quality

Unleaded gasoline only (87 AKI or 91 RON).

BMW M 5: 90 AKI or 96 RON.

This manual is supplemented by a Service- and a Warranty-Booklet. We recommend that you read these publications thoroughly.

YOUR BMW IS COVERED BY THE FOLLOWING WARRANTIES:

- Limited Warranty
- Limited Warranty – Rust Perforation
- Emissions – Related Defect Warranty
- Emissions Performance Warranty

DETAILED INFORMATION ABOUT THESE WARRANTIES IS LISTED IN BMW'S CONSUMER WARRANTY BOOKLET

"MAINTENANCE, REPLACEMENT, OR REPAIR OF THE EMISSION CONTROL DEVICES AND SYSTEMS MAY BE PERFORMED BY ANY AUTOMOTIVE REPAIR ESTABLISHMENT OR INDIVIDUAL USING ANY CERTIFIED AUTOMOTIVE PART".

Operating instructions

Hints

Vehicle care

Technical data

Index

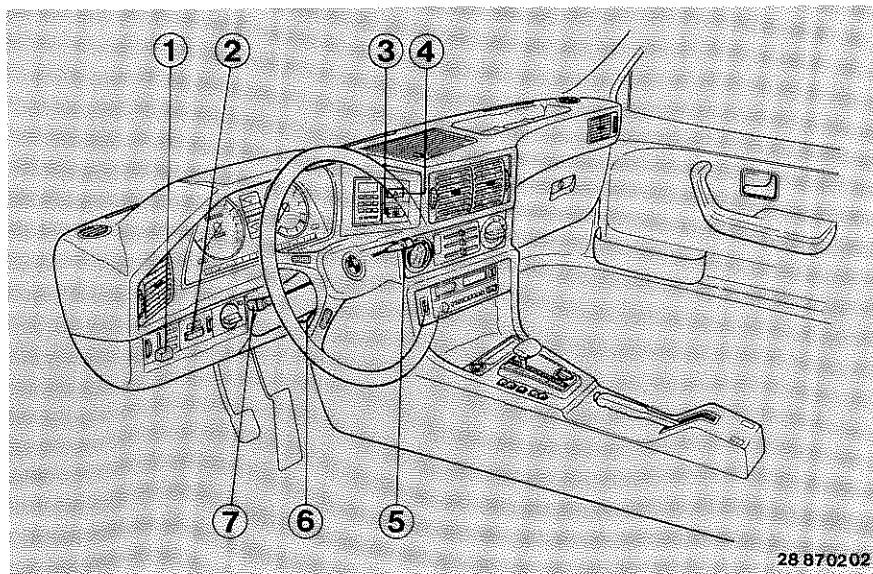

28 870202

The cockpit at a glance

- 1 – Headlight switch, see page 16
- 2 – Fog light switch, see page 23
- 3 – Pushbutton for heated rear window, see page 23
- 4 – Pushbutton for hazard warning flasher, see page 23
- 5 – Windshield wiper/washer lever, see page 18
- 6 – Steering column extension lock lever
- 7 – Steering column lever for turn indicators, low/high headlight beams, headlight flashing and change of on-board computer display, see page 17

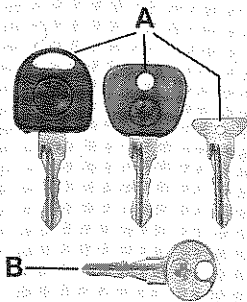

28 87 01 03

Keys

A. Master key (key for electromechanical locking system)

Key with light and battery: press button to switch on light.

Renew the battery when the light becomes dim, or else acid may leak out.

- Duplicate master key.
- Spare master key with extra-small head, to be kept in a wallet or safe place.

B. Key for doors and ignition: does not fit luggage compartment or glove box and **does not open the electromechanical locking system.**

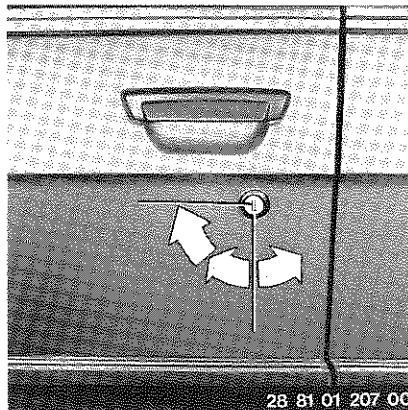

The key number on the self-adhesive label is required by your BMW dealer in order to obtain a duplicate key, keep in safe place to avoid theft.

Central locking system

Whenever the door locks or the luggage compartment lock is operated or the safety catch button on the driver's door is pressed down, the doors, the luggage compartment lid and the fuel filler flap are operated at the same time.

After an accident or hard bump the central locking system opens automatically. Reactivating follows the next operation.

Electromechanical locking system

By turning the driver's door key further to the right (clockwise) to a horizontal position, the central locking system activates an electromechanical locking system to further thwart theft.

Note: The locking device can only be operated with the master key. Do not engage this system with passengers being in the car.

To open a door from the outside: lift up the handle.

To open a door from the inside: First pull the safety catch button and then the handle above the armrest.

When the driver's door is open, its safety catch button can neither be pressed in nor the lock turned by the key. This is a safeguard against locking yourself out of the car accidentally.

Important note:

Children left in the car could lock the doors accidentally from the inside. To avoid this, make a point of removing the ignition key and taking it with you, so that the door can always be opened from the outside.



Luggage compartment

The luggage compartment can be locked separately with the master key, by inserting the key, turning it to the right and pulling it out in that position. After this, the luggage compartment can only be reopened with the master key. This is useful when the luggage is to remain locked up at all times. **If the luggage compartment is opened with the electromechanical locking system in operation, it must be relocked after closing.**

Luggage compartment light

The light comes on automatically when the lid is opened.

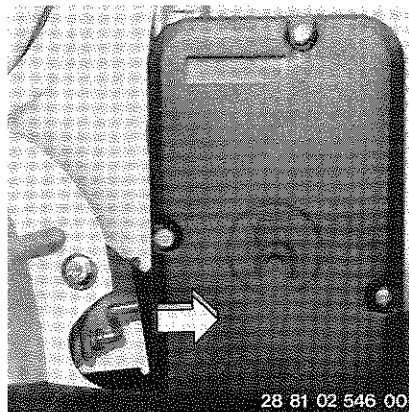

Opening of the fuel filler flap in case of a failure of the central locking system:

Press back the locking rod, accessible through the hole in the trunk lining.

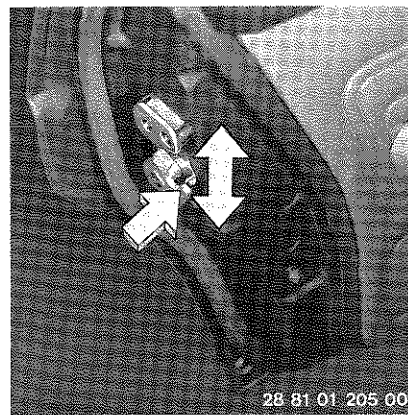

Childproof safety catch of the rear doors

Catch lever down = door can be opened from outside **but not from inside.**

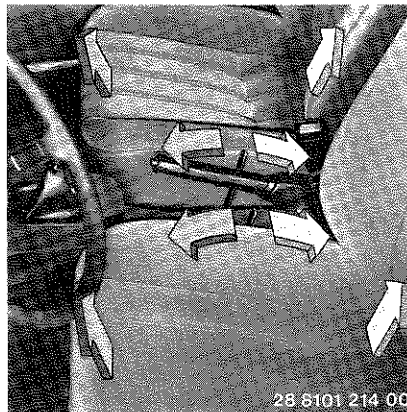
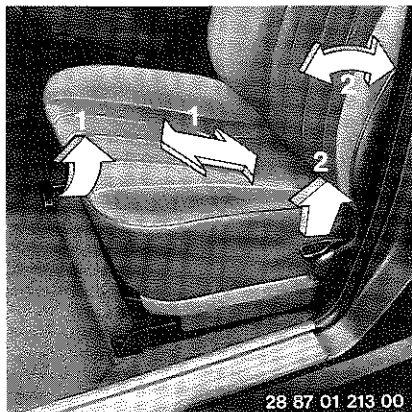

Seats

Seat adjustment

Pull up the lever (1) and exert slight body pressure to move the seat to the desired position.

Release the lever and make sure that the seat has engaged in its locking catches.

Reclining seat back

Pull up the lever (2) and exert slight body pressure to recline backward. Forward adjustment is possible by releasing the pressure.

Alteration of seat height

To alter the **height** of the front seats, move the lever on the inside of the seat base: to the front to lift or lower the front end of the seat base, to the rear to lift or lower the rear end of the seat base.

Headrest

The **headrests** can be varied in the height by pulling them upward or pushing them downward. The angle is varied by tilting the headrests forwards or backwards.

Headrests have to be positioned behind the head, not behind the neck.

WARNING! Do not adjust seat position while driving – this constitutes an accident risk.

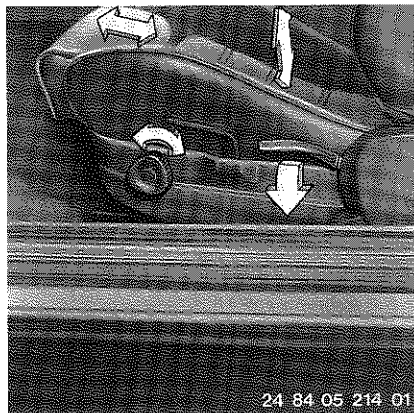

BMW sports seat

To alter the inclination

Press down the lever next to the rotating knob to alter the inclination of the seat.

Reposition of thigh support:

Rotate the knob shown to move the front edge of the seat forwards or backwards.

Alteration of seat height

Press down the lever shown to alter the height of the seat.

All other seat adjustments are done as on the normal seat.

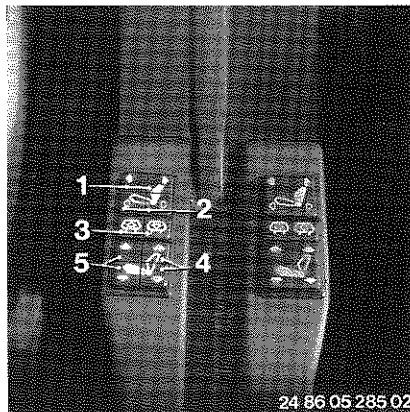

Electric seat adjustment

- 1 – raise/lower seat back angle
- 2 – move seat forwards/backwards
- 3 – raise/lower headrest
- 4 – raise/lower rear end of seat
- 5 – raise/lower front end of seat

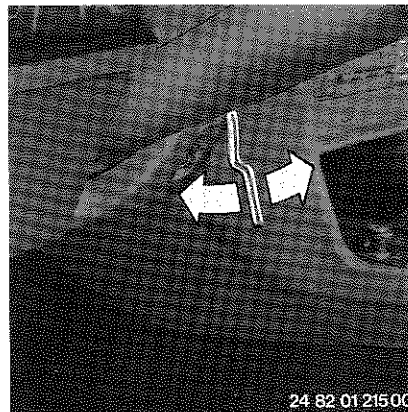

Adjustable steering column

After pulling out the clamp lever, the **steering wheel can be extended or retracted** to any desired position in relation to the seat. Secure the steering column in its new position by tightening with the clamp lever again.

Warning: Do not adjust the steering wheel position while the vehicle is in motion. This constitutes an accident risk.



Seat belts

Wear your seatbelts for every journey.

The seatbelt must be locked with an audible click. To release the belt, push in the red square marked "PRESS" pushbutton. Pull the belt across the chest and lap and be sure that the belts are not twisted. Make sure that the belt does not pass over any hard or breakable objects in your pockets or clothing. The belts ensure freedom of movement.

The belt must fit tightly against the body; that is why you should not incline the seat back too far to the rear and wear thick and heavy clothing.

Tighten it from time to time by pulling up the shoulder strap.

A reminder above the interior mirror gives you a visual warning signal and will be actuated for a time of about 6 sec when the ignition is switched on. At the same time a gong will sound. The gong will not sound, when the driver's belt is put on before switching on the ignition.

Note:

The belt locking mechanism may operate

- when taking sharp bends,
- when the car is at a steep angle,
- when pulling the belt rapidly,
- when the car accelerates or retards.

Only secure one person (over 6 years old) with each belt. Make sure that the belt does not pass over the throat.

The upper loops of the front seatbelts are attached to their uppermost mountings. These loops can be repositioned at alternative mountings which are 50 mm (2 in) lower.

Do not allow the belt to rub against sharp edges.

If seatbelts or child restraint systems are damaged or stretched by an accident, they must be replaced completely as a safety precaution.

Have the anchorage points checked by your BMW dealer.

Do not tamper with any occupant restraint system.

Care of the belts is described in Section "Vehicle care".

General remarks on seat position

Back muscles and spinal discs obtain most relief when you move right back in your seat and relax. Ideally the driver's head should be on a line forming a direct extension of the spinal column. On long journeys the seat back angle can be slightly increased, thereby further reducing the strain on the body muscles. Make sure that you are able to hold the two sides of the steering wheel with the arms slightly bent.

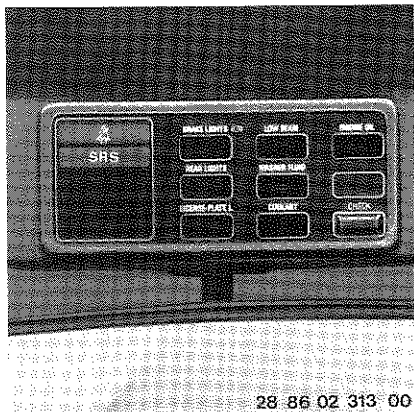

28-86 02 313 00

Supplementary restraint system (SRS)

The Supplementary Restraint System which consists of an airbag, the gas generator, the crash sensors and the control unit, is designed to supplement the three-point seatbelt and to provide additional protection for the driver in the event of a serious frontal accident.

A diagnostic system continually monitors the readiness of the squib, sensors and wiring integrity of the SRS. Monitoring begins when the ignition key is turned to position 1 (and further) and continues when the car is being driven.

If the key is turned to position 1 and left in that position, the SRS telltale in the Check-Control should illuminate for about 6 seconds and then go out.

The SRS indicator telltale should also illuminate for about 6 seconds following the engine start.

If the telltale does not light when it should or does not go out after about 6 seconds or comes on while driving or if it flutters, the system is not ready to operate during an accident; in this event have the system tested by an authorized BMW dealer as soon as possible.

Function

The airbag is mounted under the cover in the center of the steering wheel and is designed to inflate in a fraction of a second during collisions equivalent to 12 mph/20 km/h and faster frontal impacts into solid objects.

During the impact a sudden, fairly loud inflation noise will be heard and a small quantity of smoke will be released, neither of which is injurious.

Lesser impacts and those from the side and rear will not deploy the airbag, and protection will only be provided by the seatbelts.

The SRS does not replace the fastening of the seatbelts.

In connection with the seatbelt the SRS offers the best precondition for the protection of the body in case of a serious accident.

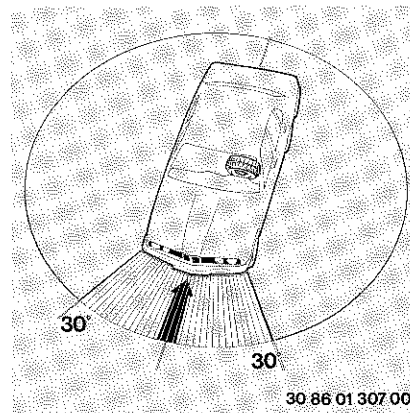

30-86 01 307 00

Tampering and improperly performed repairs can result in a failure of the system to operate or inadvertent activation.

The SRS can only be activated once. Only authorized BMW dealers should repair or replace the system.

Do not affix any labels, decorations, badges etc. to the cover at the center of the steering wheel.

Should a SRS have to be scrapped, contact a BMW dealer for the safety precautions. If you sell your car, we urge you to inform the purchaser about the system and give him this SRS handbook.

At the date specified on the label on the glovebox please have an authorized BMW dealer thoroughly inspect the entire SRS.

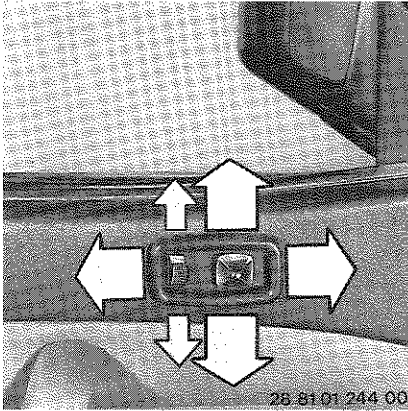

Outside mirror

Reposition horizontally and vertically by means of the mirror switch.

The glass of the **aspherical wide-angle mirror**, if fitted, is divided to improve the range of the rearward view and eradicate the "blind spot" at the rear of the car. The outer section is convex and reflects an enlarged (but slightly distorted) rear-view area. The inner section reflects the normal rear view area.

The outside mirrors are automatically electrically heated.

Righthand outside mirror

The same switch is used to adjust the mirror on the other door by first moving the changeover switch. Please take into consideration that the glass of the mirror is convex. **The objects you see in the mirror are closer than they appear.**

Manual mirror adjustment

The mirror can also be repositioned manually by moving the glass.

Interior mirror

The **interior mirror** can be moved to the anti-glare position by means of the small lever.

Map reading light

Switch on the light by means of the rocker switch.

Adjust the beam by pushing the lens to the desired position.

When **the roller sun blind** is retracted, the view in the inside mirror is adversely affected.

Note national regulations in the respect, and fit a second door mirror if required.

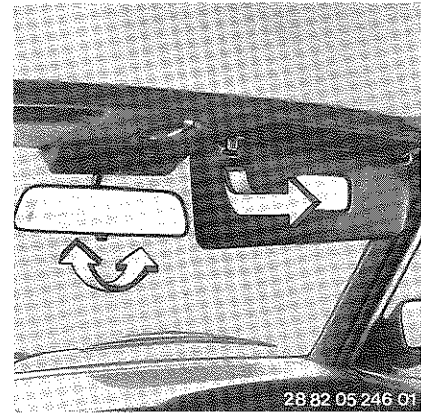

Sun visor

Each **sun visor** can also be swung around to cover the upper part of the front side window.

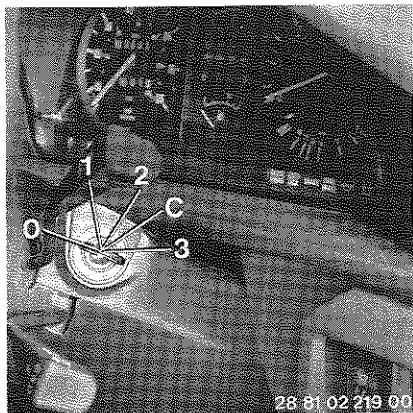

Ignition/starter switch

0 – Steering locked. The key can **only** be inserted and removed in this position.

All items of electrical equipment are switched off, except for the following, which remain operational: hazard warning flashers, lighter, interior light, side/parking lights, luggage compartment light.

To release the steering lock it may be necessary to turn the steering wheel slightly.

To lock the steering, pull out the key and turn the steering wheel to left or right until you hear the lock has engaged.

1 – Steering unlocked. Radio, on-board computer, flashing turn indicators, horn and windshield wipers can be operated.

2 – Ignition switched on. All other items of electrical equipment can be operated.

C – In this key position the red brake fluid warning light comes on. This serves for checking the function of the light. Normally, the brake light should extinguish as soon as the engine is running.

3 – Starter motor operated. As soon as the engine starts, release the ignition key. It will spring back to position **2**.

When the key is turned to this position, the brake lining telltale is checked.

Warning:

Never run the engine in an enclosed space. The exhaust contains carbon monoxide, which although colorless and odorless is extremely toxic.

Never pull out the ignition key when the car is moving, or the steering lock will engage (the steering may need to be turned only slightly) and render the car uncontrollable.

Always remove the ignition key and take it with you when leaving the car unattended. Make sure that the steering lock has engaged.

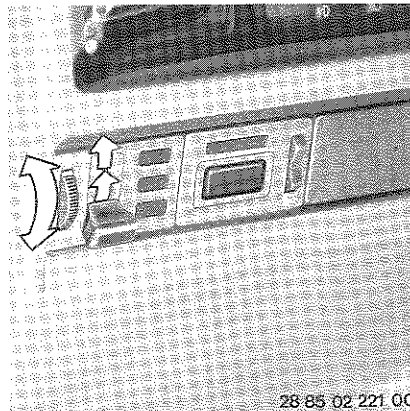

Headlight switch

Position 1: Parking lights, side marker lights.

Position 2: Headlights, parking lights, side marker lights.

If the ignition key is turned to position 1 or 0 with the headlights on, they will go out, but the parking lights, side marker lights will remain lit.

Instrument light

When the light switch is pushed to either of its two positions, the intensity of the **instrument, ashtray and control identification lighting** can be varied by turning the knurled wheel.

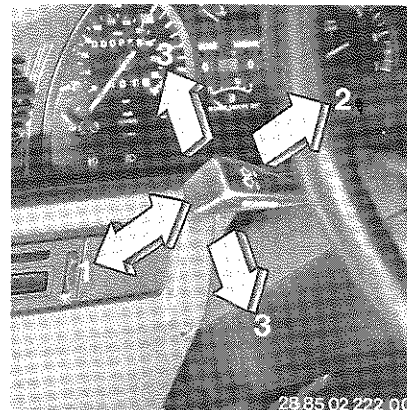
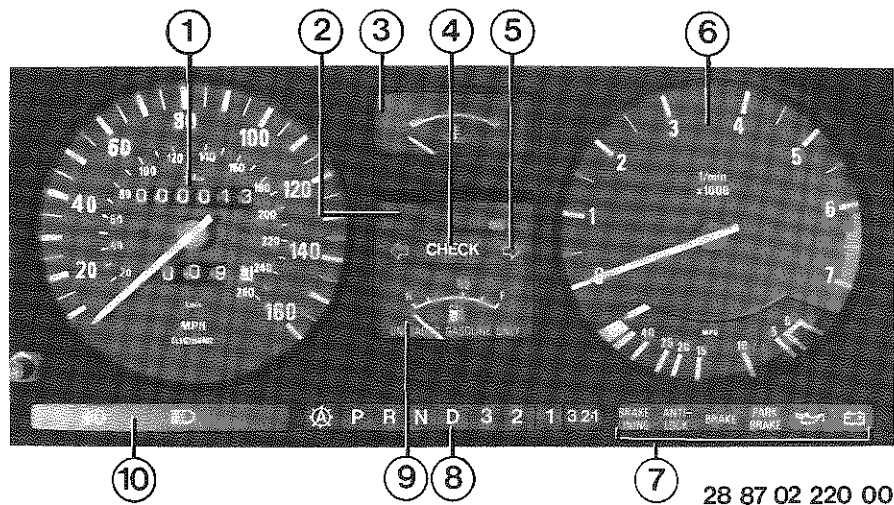

Instrument panel

	Page
1 – Speedometer with odometer and trip odometer	19
2 – Service Indicator	20
3 – Coolant temperature gauge	20
4 – Central warning light	22
5 – Turn indicator telltale	18
6 – Tachometer with fuel consumption indicator	19
7 – Warning light and telltale for Battery charge, Oil pressure, Parking brake, Brake fluid, Antilock brake system, Brake lining wear	21
8 – Automatic transmission selector lever indicator, Direct shift program, Electronic shift indicator	24
9 – Fuel gauge with low fuel warning light	20
10 – Warning light and telltale for headlight beams and Fog light	21

Turn indicator-/Dimmer switch

- 1 – Change from low-beam to high beam (blue telltale)
- 2 – High-beam flasher
- 3 – Turn indicator (green telltale)

A ticking sound will be heard in the same rhythm as the turn indicators light up, to confirm that the turn signal is being displayed.

When you return the steering wheel to the straight-ahead position, the turn indicator lever will automatically cancel.

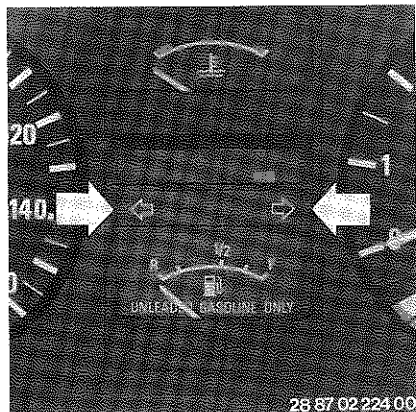

Lane change signal

To display a turn signal for a short period only – when changing lanes, passing or pulling away from the road side etc. – you need only to press the turn indicator lever slightly away from its rest position, without allowing it to engage. When released, the lever will immediately return even if the steering wheel is not turned.

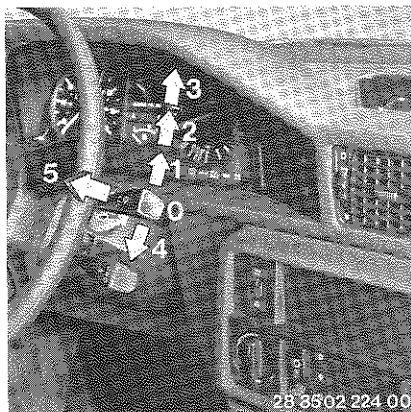

Windshield wiper-wash lever

- 0 – Wipers off
- 1 – Intermittent wipe
- 2 – Normal wiper speed
- 3 – Fast wiper speed
- 4 – Single wipe
- 5 – Automatic wash-wipe system

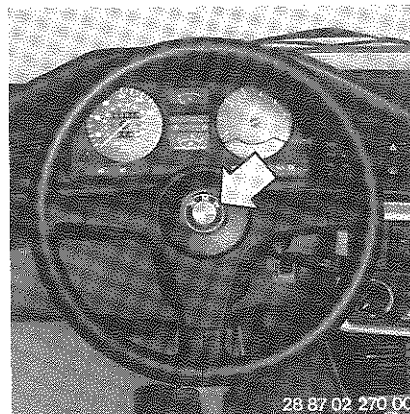

Electric horn

The electric horns are sounded by pressing the horn button in the steering wheel.

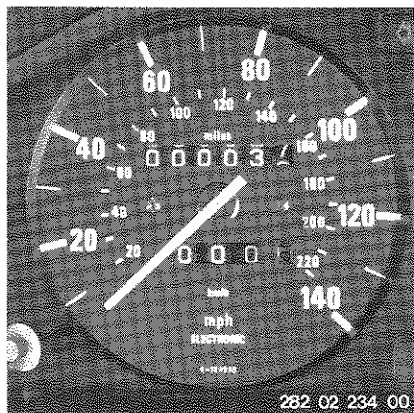

Speedometer

US model

The outer scale of the **speedometer** is calibrated in miles per hour. The inner scale is calibrated in kilometers per hour.

The speedometer contains an odometer to show the total number of miles the car has covered.

Trip odometer

The **trip odometer**, which is used to record journeys up to 999.9 miles can be re-set to zero by pressing the knob.

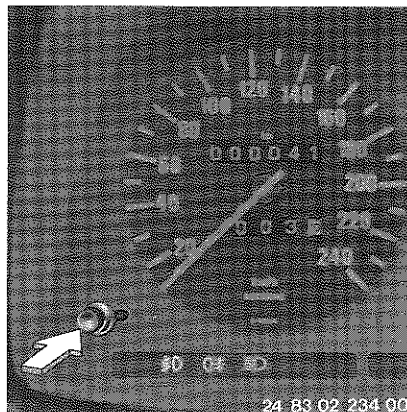

Canadian version

In this version the scale of the speedometer is calibrated in kilometers per hour.

The odometer registers the distance in kilometers.

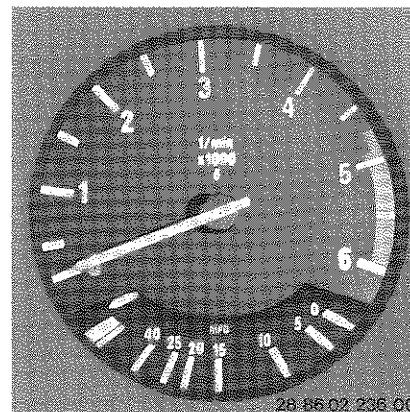

Tachometer

Avoid excessive engine speeds in any portion of the red warning zone, particularly when driving downhill or in lower gears.

The **fuel injection control unit** incorporates a cutout to limit maximum engine speed. This takes effect when the needle of the tachometer reaches the red warning zone.

Fuel consumption indicator

Above app. 13 mile/h (20 km/h), you can read the fuel consumption corresponding to your style of driving at any speed.

Below app. 13 mile/h (20 km/h), the indicator will tend towards the zero (in Canada to the maximum) reading as speed is reduced, and will come to rest there when the car is stopped.

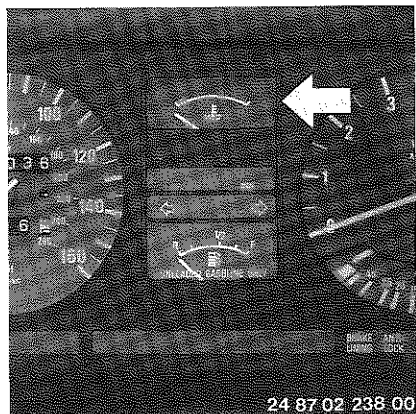

Coolant temperature gauge

Blue: engine has not reached normal operating temperature. Drive only at moderate road and engine speeds.

Red: engine overheated – pull over to a safe area out of the mainstream of traffic and stop engine immediately. Allow system to cool down until temperature gauge indicator is approx. in the middle of the scale.

Normal operating temperature is between the two colored zones. The needle may tend to reach the red zone when the ambient temperature – and/or the engine load is very high.

Check coolant level, see page 48.

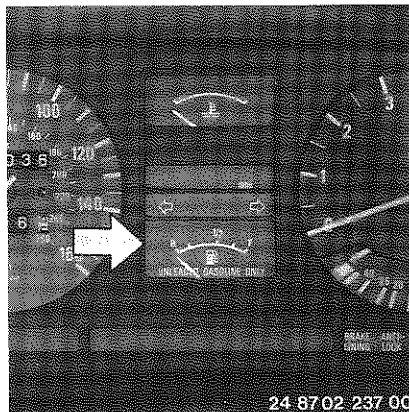

Fuel gauge

If the yellow low fuel warning light comes on, there are approx. 1,8 gal./7 l fuel left in the tank.

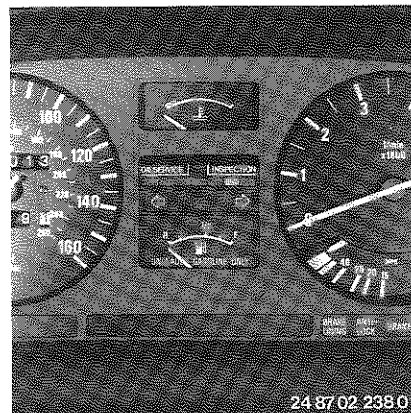

Service indicator

Green LEDs

As the number of illuminated green LEDs becomes less, this is an indication that the next service is shortly to fall due.

The green LEDs go out when the engine is started.

Yellow LED

If the **yellow LED** and one of the inscriptions, OIL-SERVICE or INSPECTION, also comes on with the ignition and remain on when the engine has been started, the next service routine is due.

Red LEDs

The maintenance interval has been exceeded.

Resetting is done after maintenance.



Telltale- and warning lights

1 – Fog light telltale

If fog lights are fitted and switched on the telltale comes on.

2 – Headlight high beam telltale

The blue telltale lights up when the high beam or the headlight flasher is switched on.

3 – Brake lining wear indicator telltale

Light goes out after engine has started.

Minimum brake pad thickness is indicated by means of a red **brake lining wear telltale** in the instrument cluster. As a check this light comes on in ignition key position 3 when the engine is started.

If the warning light comes on have the brake pads inspected without delay.

4 – Antilock brake system telltale

Light goes out after engine has started.

If the **antilock warning light** comes on when the car is in motion at normal driving speeds, this indicates that the antilock braking system has developed a fault and is out of action. Although the antilock braking effect is then lost, normal brake applications can still be made.

5 – Brake and steering hydraulic system warning light

Light goes out after engine has started.

The warning light performs two information functions:

- If it **comes on** and burns steadily, brake fluid level is too low.
- If it **flashes**, this indicates loss of pressure from the power steering circuit or the brake system pressure reservoir (BMW 535 i/S; M 5).

We recommend you have all problems in the brake system examined and repaired immediately.

6 – Parking brake telltale

When the parking brake is applied the red telltale in the instrument cluster will come on.

7 – Oil pressure warning light

Light goes out after engine has started.

If the **red oil pressure warning light** comes on while driving, pull off the road to a safe stop and declutch or select neutral immediately and switch off the ignition. If the engine oil level appears to be incorrect, do not drive the vehicle. Operating the vehicle with low or no oil pressure will cause severe engine damage.

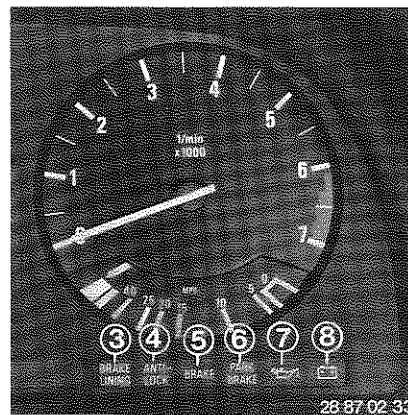

If the warning light comes on briefly at idle speed this should cause no alarm provided that it goes off when the accelerator is pressed down.

8 – Battery charge telltale

Light goes out after engine has started.

If the **red battery charge telltale** comes on during a journey, have the car checked as soon as possible to determine the cause of the problem or else the battery may eventually discharge completely.

If the V-belt is defective, the coolant pump is inoperative.

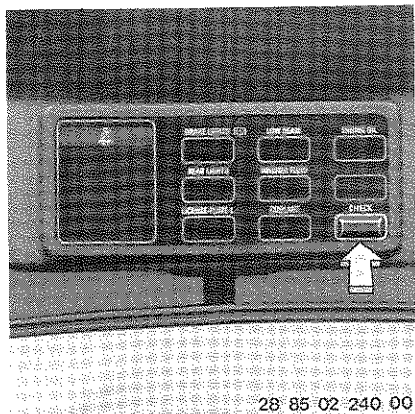

Check-Control

The functions of

- License plate light
- Fasten-seat-belts reminder
- Brake (stop) lights
- Dipped/low beam
- Rear lights

and the liquid levels of

- Coolant
- Washer fluid
- Engine oil

are checked.

Ignition/Starter switch position 1

Any reduction in engine oil, coolant or windshield washer fluid level is indicated by the inscription panel being illuminated, and the appropriate LED coming on.

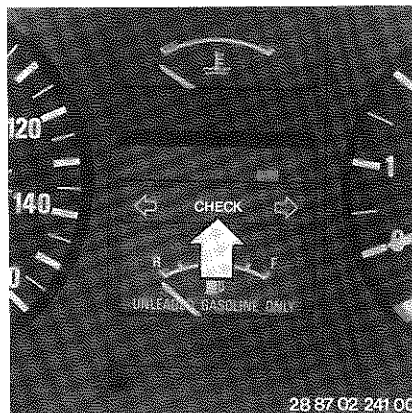

Ignition/Starter switch position 2

The central warning light on the instrument panel will flash. At that same time, all Check Control inscriptions light up, together with the "Brake lights" warning light.

If the engine is started and the car's lights turned on, any malfunction can be identified immediately by means of the appropriate warning and indicating lights.

If the brake pedal is depressed, the central warning light, the "Brake lights" warning light and all Check-Control inscriptions should go out if the corresponding systems are in proper working order.

Central warning light flashing while driving

Warning light for the faulty systems in the Check-Control lights up.

Switch off central warning light: Press check key.

When the check key is pressed, all the warning lights will come on, but when released only those indicating a genuine system malfunction will remain on.

Top up fluid levels if too low at the earliest opportunity.

If the engine oil level is too low, this indication remains stored in the Check Control memory until oil is added.

Any malfunctions of the car's lights should be rectified immediately, depending on their significance for road safety (brake lights!).

Rectify malfunctions as following

- **Brake (stop) light operation:** Replace the appropriate electrical fuse or spherical brake light bulb.
- **Low beam-operation:** Replace the appropriate electrical fuse or the sealed beam.
- **Engine oil level:** Check level and if necessary add fresh oil of the same grade.
- **Rear light-operation:** Replace the appropriate electrical fuse or the bulb.
- **Washer fluid level:** Top up the windshield washer fluid tank and if necessary restore the concentration of the antifreeze.
- **License-plate light-operation:** Replace the appropriate electrical fuse or the bulb.
- **Coolant-level:** Check level and fill up if necessary. Afterwards check the concentration of the long life antifreeze and corrosion inhibitor.

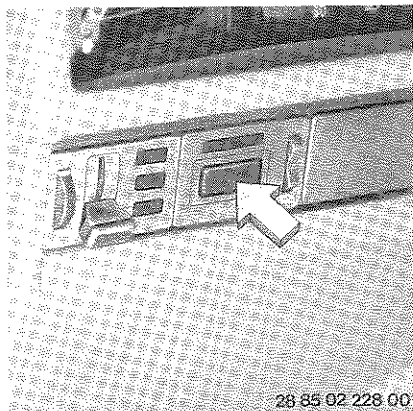

Fog light switch

To switch on the front fog lights, press in the pushbutton.

Whenever the **front fog lights** are in use, a yellow telltale on the instrument panel comes on.

Please note national regulations with regard to the use of fog lights.

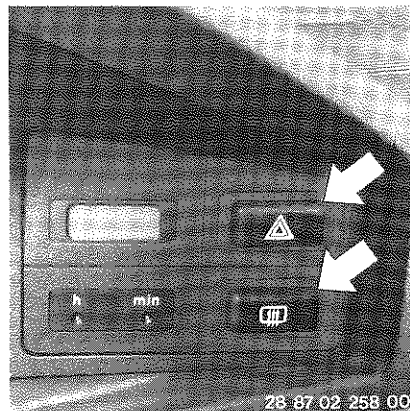

Hazard warning flasher

The **hazard warning flashers** are operated by the pushbutton with the "triangle" symbol; its red telltale flashes rhythmically when the hazard warning system is in use.

When the car's lights are turned on, a bulb is illuminating the pushbutton switch.

Heated rear window

When the **heated rear window** is switched on, the yellow telltale in the pushbutton comes on.

The electric heating elements on the rear window ensure unrestricted vision to the rear and help to prevent or remove fogging or ice build-up in freezing conditions.

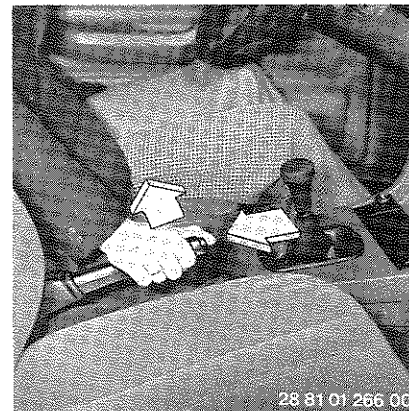

Parking brake

The parking brake operates on the rear wheels. To stop the vehicle and prevent it from moving pull the parking brake lever up. To release the lever, pull it up slightly, press in the knob and push the lever down.

When the parking brake is applied the red telltale in the instrument cluster will come on.

A useful hint: to avoid noise from its ratchet when applying the parking brake, press the knob in as the lever is pulled.



Manual transmission

5-speed gearbox

The fifth gear is an economy gear, reducing engine speed and noise level as compared with fourth gear while maintaining road speed, and may contribute to fuel consumption reduction.

All gears have synchromesh. When disengaging any gear, the gear lever automatically slips back into neutral position between 3rd and 4th gears.

The neutral position of the gear lever is indicated by a spot on the gate pattern.

Selecting reverse gear

It is advisable to select reverse when the car is at a standstill.

The backup light will come on when the reverse gear is selected and the ignition is switched on.

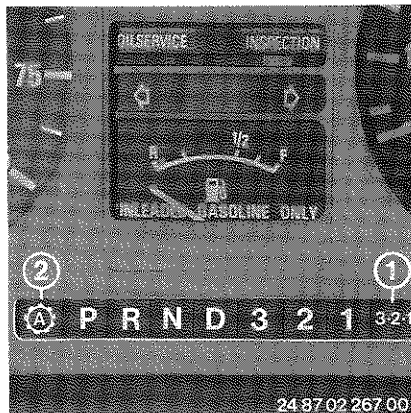

Automatic transmission

The following selector lever positions are available for various traffic conditions.

P-R-N-D-3-2-1

The lever position selected is shown by symbols on the selector lever gate.

For engine starting, move selector lever to position P or N.

On the electronic-hydraulic transmission, 3 additional shift programs can be selected at the program switch:

E	(Economy)
S	(Sports)
3 · 2 · 1	(Direct)

Please note that starting the engine is only possible in selector lever position P or N.

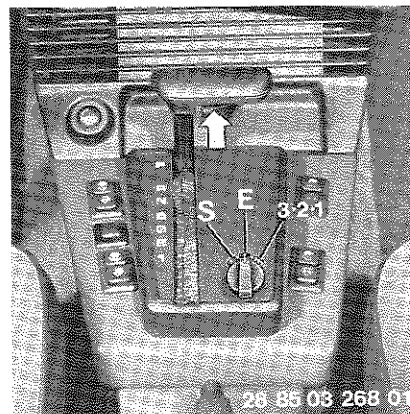

Pull up the release catch under the lever handle if necessary.

Important: after selecting any lever position wait for the transmission to engage especially at low temperatures (slight drop in engine speed) before accelerating.

The car tends to crawl if the engine is running at idle speed and a drive gear is engaged.

Before leaving the car with the engine running, first select P or N at the selector lever and apply the handbrake.

P = Park

Select only when the car is standing still.

The transmission is locked in this position as an additional precaution against rolling away.

R = Reverse**N = Neutral**

There is no connection between the engine and the transmission. Select this position during **prolonged periods of idling** (for instance in traffic jams).

To prevent excessive clutch plate wear, do not select this position when driving unless absolutely necessary (e. g. to prevent skidding).

If it happens accidentally release the accelerator immediately and select the new position.

D = Drive (automatic gear selection)

This is the position for all normal driving. The car starts in 1st gear and shifts up automatically.

The 4th speed range is designed as an overdrive, to reduce engine speed, engine noise and fuel consumption once a steady road speed has been achieved.

3 = Direct drive position

Should under certain driving conditions in city- or highway driving gear changing between the range 4–3–4 occur, shift to this position. Automatic shifting will be limited to the gear 1 to 3 and reverse. This excessive shifting between the ranges could be caused by the overdrive feature. If increased performance is needed, shift to this more sporty range.

2 and 1 = Hill-climbing and engine braking

This position may suit the driver better on mountain roads or very long uphill and downhill gradients. It makes better use of full engine performance and the engine's braking effect.

Position 2 and 1 can be selected at any speed, after releasing the safety catch under the handle. However, the transmission will not shift down immediately into 2nd and 1st as this would cause excessive engine rpm.

Note that once position 2 or 1 has been selected, the transmission will no longer shift up to a higher speed range, even if this means that the engine can overrev.

“Kick-down”

After reaching the normal full-throttle position, the accelerator pedal on automatic transmission cars can be depressed further.

This will enable maximum acceleration to be obtained immediately by selection of lower gears.

After the kick-down has been operated, the next upward shift will occur only at a much higher engine speed than usual.

For tow-starting and starting with a dead battery, see page 50.



Program switch for electronic-hydraulic transmission

E = Economy program

Once the car has been started, this program can be selected for low fuel consumption motoring.

S = Sports program

This is the program for an enthusiastic driving style. The gear shift points are delayed to make full use of the car's power reserves.

3 · 2 · 1 = Direct shift program

This program (telltale 1) is for single-gear driving (3rd gear if D is selected). The gear selected is also used for pulling away. For example, if the selector lever is in position 1, for tackling steep gradients or when towing a trailer, no undesirable upward gear shifts will take place. The same applies to driving on icy roads in winter: with the selector lever in position 3, you can pull away smoothly and no gear shifts will occur.

Electronic shift control telltale (2) comes on: Electronic shift control circuit has failed. The transmission selects 3rd gear irrespective of the selector lever position.

The car can be driven normally. Consult nearest BMW dealer (avoid high engine loads).

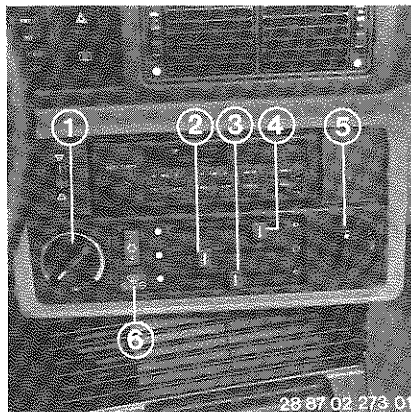

Heating and ventilation

The controls are arranged as follows:

- 1 – Temperature control
- 2 – Slide control for fresh air entry
- 3 – Slide control for air distribution to lower part of interior
- 4 – Slide control for air distribution to upper part of interior
- 5 – Blower control
- 6 – Diagram-showing control setting for maximum windshield defrosting

Outlet grilles for variable-temperature air:

Variable-temperature air enters the car through the defroster outlets and the front and rear footwell outlets.

Outlet grilles for outside air:

Outside air enters through the grilles above the controls and at the right and left side of the fascia.

1 = Temperature control

When turning this control clockwise the temperature will increase.

Automatic temperature control

The temperature scale acts as a guide when adjusting the control to obtain a pleasant interior temperature. This temperature will then be reached after starting the journey, and no further adjustment of the temperature control should normally be necessary.

To prevent undesirable fluctuations in temperature, alter the previous temperature setting only slightly at first.

The automatic temperature control system is off at the two limits of rotary switch movement.

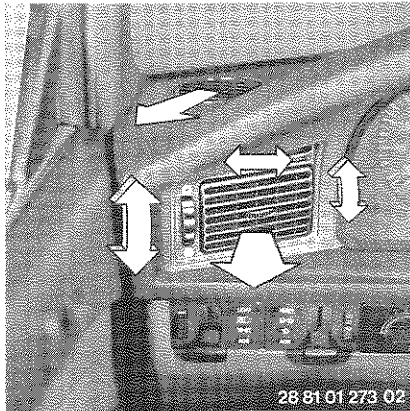

2 = Slide control for fresh air admission

As the lever is slid from the left (closed) to the right (fully open), an increasing amount of outside air is admitted to the car.

The air outlet grilles above the controls and at the left and right of the fascia can be turned horizontally and vertically, or closed by turning the knurled wheels at the side of the grilles down.

If the footwells are supplied with heated air at the same time, a stratified temperature pattern will be obtained inside the car (warm feet, cool head and upper body), which is conducive to fatigue-free driving.

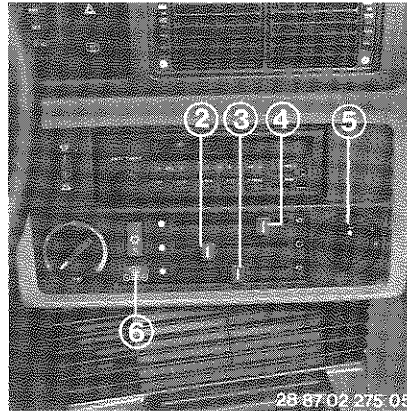

3 = Slide control for air distribution to lower part of interior

4 = Slide control for air distribution to upper part of interior

By moving these levers from the left (closed) to the right (fully open), the desired pattern of variable-temperature air can be obtained and continuously varied as required.

The lower air distribution lever should always be left at least half open (unless the windows have to be defrosted), so that the temperature sensor can deliver the necessary warmer or cooler air to maintain the chosen constant-temperature setting.

If variable-temperature air is supplied only to the upper outlets, this will raise the temperature at the defroster outlets and keep the windshield and front side windows clear.

5 = Blower control

This enables the volume of air entering the interior to be varied; the flow is boosted when the switch is turned clockwise.

Effective operation of the automatic temperature control system is only ensured if the blower is run.

It is recommended to run the blower whenever heating or ventilation is required, particularly at low or extremely varied speeds.

6 = Mimic diagram for maximum windshield defrost settings

The settings shown on this diagram will clear the windshield and front side windows as rapidly as possible if iced over or steamed up.

Maximum efficiency is obtained when the engine has reached its normal operating temperature.

Air extraction

Stale air from the car's interior is expelled through slots below the rear window, and emerges at openings on the rear roof pillars.

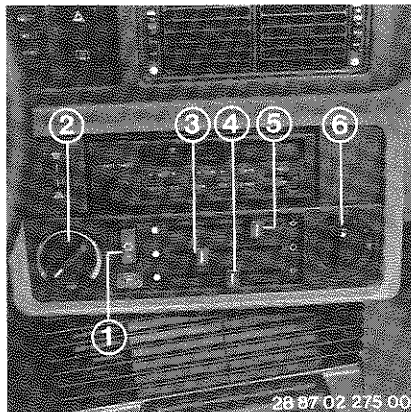

Air condition

The air conditioning system is integrated into the ventilation system, with air distributed through the directional side and center grilles which can be shut off.

1 = Air conditioning pushbutton

The air conditioning is switched on and off by this button above 5° C/41° F (sensor at the evaporator) while the ignition key is in position 2.

2 = Rotary temperature control

The temperature scale is a guide to the most pleasant interior air temperature, and in this case permits the interior to be cooled as well as heated.

When the air conditioning is switched on, air entering the interior is cooled in the blue zone on the control knob, reaching a maximum at the left limit of control movement.

3, 4, 5 = Sliding levers

The air conditioning being switched on the sliding levers are without function.

6 = Rotary blower switch

This permits the volume of air entering the car to be varied. Turning clockwise boosts the airflow.

When the air conditioning is switched on, a small amount of cool air enters even at blower switch position 0.

Condensation which forms at the evaporator is discharged underneath the car. According to humidity, up to 2 litres (3.5 pints) of water may form per hour.

Important notes:

- The air conditioning system operates only when the engine is running.
- When the air conditioning is switched on, at least one air outlet grille must be open, or else the evaporator may ice up.
- **The air conditioning should be run briefly at least once a month particularly important during the cold season of the year, or else the compressor shaft seals may dry out and allow refrigerant to escape.**
- If any malfunction of the air conditioning is noted – for instance no cool air output after switching on – the system should be switched off at once and the car taken without delay to a BMW authorized dealer for air conditioning repairs.

The addresses of BMW service stations for air conditioning repairs appear in your "BMW SERVICE" list.

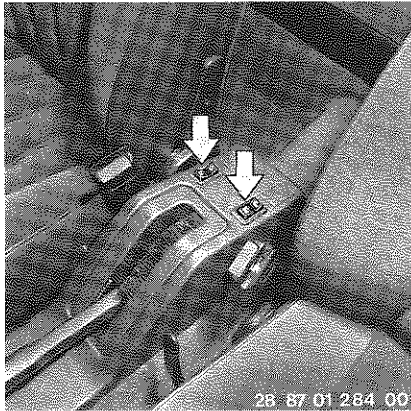

Front-seat heating

The **electric front-seat heating** is operated by rocker switches.

Switch ●● pressed – seat warms up
 Switch ● pressed – seat is kept warm.

Best results are obtained if the seat is heated for about 5 minutes and then kept warm.

The green telltale lights in the pushbutton switches light up when the heating is in operation.

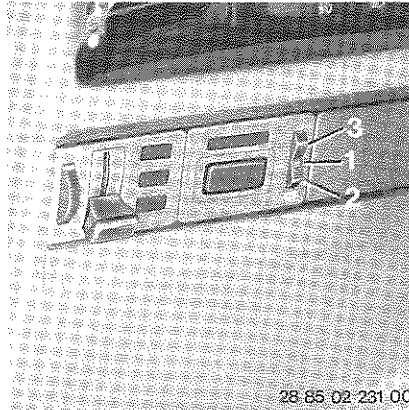

Interior light switch

Position 1: light is on only when a door is open.

Position 2: light permanently off.

Position 3: light permanently on.

The **interior light** is automatically switched on by lifting the driver's door handle. The interior light remains on for about 6–8 seconds after the doors have been closed, but goes out when the ignition is switched on.

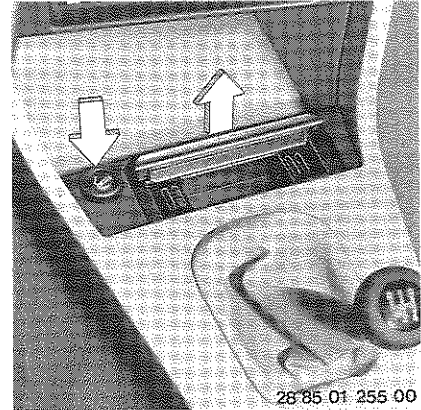

Lighter

To use the **lighter**, press in the knob. When the heating element has become sufficiently hot, the knob will pop out and the lighter can then be removed from its socket.

The power **socket** can also be used to plug in a hand lamp, electric shaver or similar appliance rated at not more than 200 Watts, 12 Volts. Make sure that the socket is not damaged by attempting to insert plugs of the wrong pattern.

Front ashtray

To clean the front **ashtray**: open the flap and pull the whole assembly up.

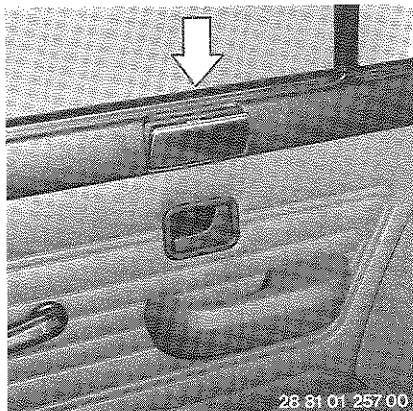

Rear-seat ashtray

To clean the ashtray: open the flap, press down and remove the whole assembly.

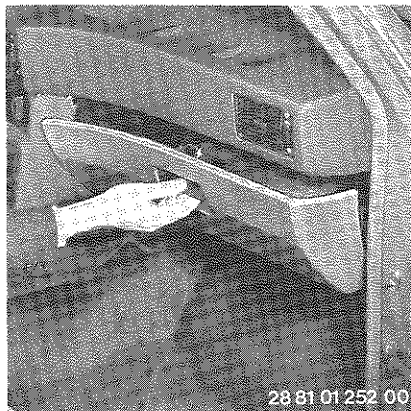

Glove box

The lockable glove box is opened by pulling the recessed handle and closed by pushing the lid up firmly.

When the glove box lid is open, the glove box light will come on and the **rechargeable flashlight** can be reached. The flashlight has a built-in overload device and can thus remain plugged in at all times so that it is fully charged whenever needed.

Warning: Do not plug the lamp in while it is still switched on.

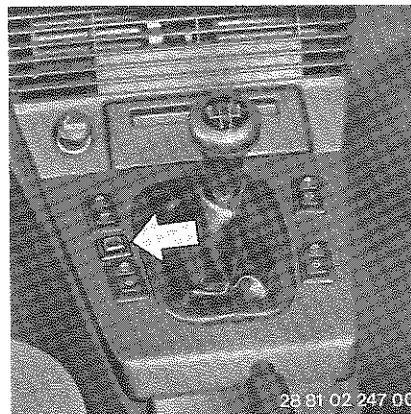

Electric window lifts

The electric window lifts are operated from the pushbuttons on the center console, when the ignition switch is in position 2.

There are additional switches under the rear side windows to operate them separately, but these can be isolated with the driver's Circuit breaker, for instance to prevent children from playing with the windows.

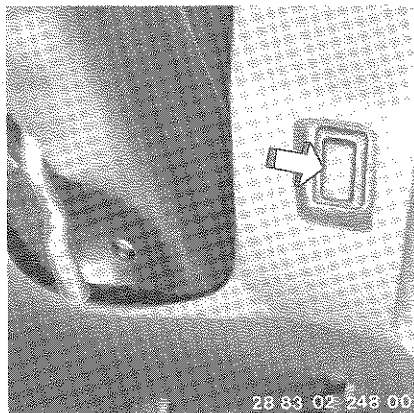

Automatic circuit breaker

An automatic circuit breaker and a fuse protect the electric window motor by tripping in the event of a fault or overload.

The electric windows are not operational when the ignition key is removed, to prevent children left in the car from operating the windows and perhaps injuring themselves.

For manual operation of the windows in an emergency, see page 54.

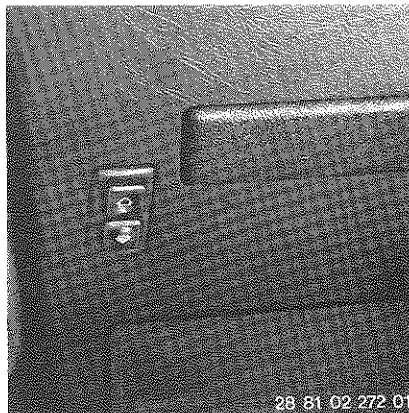

Sliding/vent sun roof

Lowering or opening (sliding back): press the rear pushbutton.

Raising the rear end of the panel or closing the roof (sliding forwards): press the front button.

Sliding and elevating operations are separated by an electrical changeover switch. After the roof has been slid shut, the drive motor will cut out automatically. If the roof is to be raised at its rear end immediately after sliding closed, the switch must be pressed a second time. The same applies when changing over from lowering to sliding open.

Before leaving the car, switch off the electric sliding roof mechanism by taking out the ignition key. This will prevent children left in the car from tampering with the controls and possibly incurring injury.

If the electrical system should fail, the sliding roof can be closed manually. See page 54.

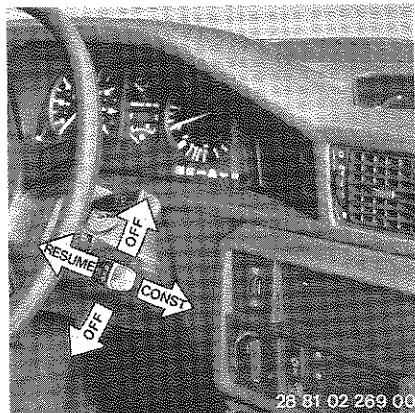

Automatic cruise control

This system allows adjustment for a constant cruising speed in the speed range above 28 mph or 45 km/h.

“CONST” (Constant)

Cruising speed will be set, held and memorized. By holding the lever in this position your BMW accelerates without using the accelerator pedal. After releasing the lever the achieved speed will be maintained and also “memorized”.

The accelerator pedal can still be used to increase speed, for instance on a steep hill or when overtaking, but when it is released the cruise control will return the car to the speed previously selected.

“RESUME”

The last “memorized” speed will be resumed.

“OFF”

By moving the control lever either in a downward or upward direction the cruise control can be switched off in any driving and operating condition. The last memorized speed can always be resumed by moving the lever to “RESUME”. The “memorized” speed is cancelled by switching off the ignition.

The cruising speed control is automatically switched off in any operation when using the footbrake, or the clutch, by moving the gear selector lever from D to N, or if the deceleration rate exceeds 1.5 m (4.9 ft)/s², for instance on a steep hill.

Warning

Never use the automatic cruise control if:

- you are in heavy traffic
- the road is winding and where a constant speed cannot be maintained
- the road surface is slippery – **rain, snow, ice**
- the road surface consists of a loose driving surface – **gravel, dirt, sand**.

On-board computer

The on-board computer can supply the following information for safe and economical driving:

– Time or date

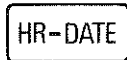

– Average speed

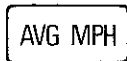

– Speed limit warning



– Average fuel consumption



– Range on remaining fuel



– Vehicle immobilization for anti-theft protection



– Stopwatch



– Outside (ambient) temperature

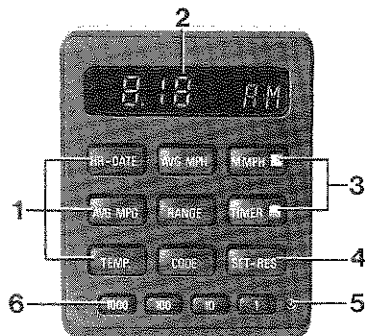
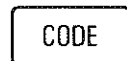

1 – Information buttons (rows 1–3)

2 – Digital display

3 – Light-emitting diodes (LEDs)

4 – “Start-Stop” button

5 – Changeover contact

6 – Four numerical input buttons (row 4)

The computer is ready for use at ignition key position 1 and beyond.

For safety reasons, always **input information before** beginning a trip or with the vehicle at a standstill.

Press the appropriate “information button” to obtain the following displays:

- Average speed
- Average fuel consumption
- Range on remaining fuel
- Outside temperature

The selected information display will remain on until another display button is pressed.

After pressing one of the information buttons, press the SET-RES button (4) to reset the computer to begin recomputing

- Average speed
- Average fuel consumption
- To start and stop the stopwatch function

The entering of numerical inputs for:

- Time/date
- Speed limit warning
- Vehicle immobilization for anti-theft protection

are described on the following pages.



28 85 01 279 01

Press the appropriate information button to obtain a new information displayed.

By pressing the turn signal lever in the direction shown in the figure below, the display will change to the next function.

Press the turn signal lever consecutively until the desired function is displayed.

As an added feature for diplomats and foreign travel, the information can be displayed in U. S. imperial (British), or metric units of measure and language. To change the units of measure and language, press the AVG MPG button and then press the changeover contact (5) with the tip of a ball point pen. Each time the changeover contact is subsequently pressed, the units of measure and language will change and will be shown on the display. (During the changeover, the measuring units for fuel consumption appropriate to the country are displayed.)

If the power supply to the on-board computer is interrupted during electrical repairs, e. g. changing a battery, all data stored is erased from the memory and the units of measure and language will change to the metric automatically.

When the supply voltage is restored, the units of measure should first be selected, then the time, date, and if desired, the speed limit programmed as outlined on the following pages.

Should the display indicate AAAA or PPPP, contact your dealer.







Input and information displays



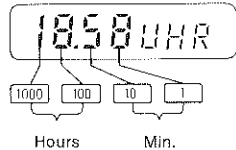



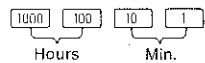



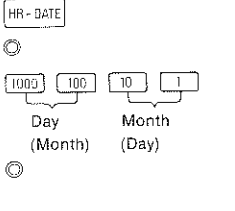

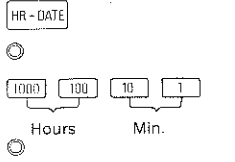

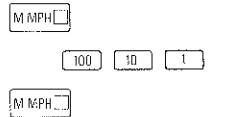













Use these buttons to program the digits in the display as outlined on the charts below. The memory will not, however, accept unattainable inputs such as a 13th month, etc.

When a digit is entered, the previous digit stored in the memory is erased. Digits can be changed individually and in any order.

When a button is pressed (or after each half second if the button is held in), the corresponding display digit increases by one digit.

Function	Input: press buttons in the sequence shown below	Information display: Press button shown below for display of function desired	Notes: Programming information and display description
Change of language and units of measure	 <input type="radio"/> Changeover contact (5)	According to input	Before the vehicle is used for the first time or if the power supply has been interrupted, the first display will be in metric units of measurement (... UHR). Press changeover contact once for US (MPG) Press changeover contact twice for Imp. (M/G) Press changeover contact thrice for metric units (L/100)
Time — initial input (or after electrical repairs)	<input type="radio"/> Changeover contact (5)  <input type="radio"/> Changeover contact (5)		Before the vehicle is used for the first time, and after a break in the power supply, ---- UHR appears in the display. Input the time with the display showing 0000 UHR. The clock starts to run as soon as the dot between the hours and minutes appears.
Country-specific initial time input AM/PM	 <input type="radio"/>  <input type="radio"/>   <input type="radio"/>		The display shows 1200 AM. Press the 1000 button twice to alter display from AM to PM; If the time has already been input, press CONSUM. to obtain the display in another language. Then press the changeover contact and blend in the time display by pressing the HR-DATE button. The change to AM/PM is automatic.

Function	Input: press buttons in the sequence shown below	Information display: Press button shown below for display of function desired	Notes: Programming information and display description
Date			<p>Input of the date on a new vehicle (or after electrical repairs) is only possible after the clock has been set and the display shows "0000 DATE".</p> <p>For correction of an error, follow procedures outlined under "correction (Time and Date)" below.</p> <p>The date function begins to operate when the dot appears between month and day.</p> <p>To obtain the date from a different information display, press the HR-DATE button twice. Note: The metric display only is in the sequence (day) (month).</p>
– Correction (time and date)			<p>Press the HR-DATE button for corrections only if other than the desired display is shown.</p> <p>Press the changeover contact to erase the dot (between month and day or between hours and minutes). Input the correction. Press the changeover contact to restart the function and the dot will reappear.</p>
Average speed			<p>Press buttons in sequence shown anytime to begin re-computing average speed. However, if during a trip the average speed is already displayed, it is only necessary to press SET-RES</p>
Speed limit warning			<p>If the input speed limit is exceeded, the LED flashes and a gong sounds. Press the information button again to switch off the speed limit warning: the LED will go out, but the speed value in the memory is retained. When changing to a different language/unit of measurement, the memory is erased.</p>

Function	Input: press buttons in the sequence shown below	Information display: Press button shown below for display of function desired	Notes: Programming information and display description
Average fuel consumption	 		Press buttons in sequence shown anytime to begin recomputing average fuel consumption. However if during a trip the average fuel consumption is already displayed, it is only necessary to press SET-RES.
Range	-		A plus sign (+) before the value displayed indicates a full fuel tank and a range higher than that displayed.
Stopwatch - Start	 → 	-	Press timer button for stopwatch function. Press SET-RES to start stopwatch. When stopwatch is running, the LED lights up.
- Stop-watch display	-		If the stopwatch is running (LED lit) and another display is shown, press time button to display stopwatch.
- Stop	 → 	-	When other than stopwatch is displayed, press buttons shown to stop. If stopwatch is displayed, press SET-RES to stop.
Ambiente temperature	-		When the temperature drops to 37 F (+3° C), a gong sounds. The temperature is automatically displayed for 8 seconds if a display other than temperature has been selected.
Anti-theft protection - to active and immobilize car	Ignition key to 1      Ignition key to 0	-	Follow sequence shown and enter any "code" from 0000 to 9999. Turn ignition to position 2 to cancel. In case of error, repeat sequence. Memorise the code number!
- to cancel	Ignition key to 1 or 2     Input code numbers:  or start engine	-	Warning: if 3 incorrect inputs are made consecutively, or 3 attempts are made to start the engine, a horn sounds for 30 seconds.

Further information on the on-board computer

(Changes in information programs are only possible after pressing the relevant information button).

HR-DATE

Dual function Button. The time and date are displayed alternately by pressing the button. After initial connection to the power supply, 4 flashing segments will appear in place of the time or date display. Inputs can be made after pressing the changeover contact (5) with a ball-point pen (0000 AM/PM display).

To correct the time or date, press the changeover contact (5) until the dot (between the hour and minutes or month and day) disappear(s). After the correct time/date has been set, press the changeover contact (5) again to restart the clock/day counter. The dot will then reappear.

The clock can be set to an accuracy of 1 second by pressing the changeover contact (5) when a radio time signal is heard.

The date display disregards leap-years and must be corrected manually as appropriate. When changing to a different language, the time and date displays are altered accordingly.

AVG MPH

The current average speed is displayed when the button is pressed. Press SET-RES to restart the average speed calculation anytime, e. g. before starting a new trip.

M MPH

New speed limit values can be input or displayed. Press the button again to set the speed limit warning; the red LED will light up. If the input speed limit is exceeded a gong will sound and the red LED will flash.

The gong will sound again if the difference between input limit speed and actual travel speed was greater than 3.1 mph (5 km/h) at least once since the gong first sounded. To cancel the speed limit warning, press the button again; the red LED will go out. The memory is erased when changing over to a different language/unit of measurement.

AVG MPG

Current average consumption is displayed when the button is pressed. Press SET-RES to restart the average fuel consumption calculation anytime, e. g. before starting a new trip.

The on-board computer can be switched to a different language/unit of measurement by pressing this button and then the changeover contact.

RANGE

By pressing this button, the estimated distance which can still be covered with the fuel remaining in the tank is displayed. Below a range of 15 km (9.3 miles), a flashing four-segment display indicates that more fuel is urgently required.

The on-board computer only registers the addition of fuel in ignition key positions 1 and 0, and when at least 5 litres (8.8 pints) of fuel are added.

A plus sign (+) before the display indicates that the car has a greater range than that indicated, as a result of "overfilling" the tank.

TIMER

The stopwatch is started and stopped by pressing the SET-RES button. The red LED lights up to show that the stopwatch is running. Travel, standstill and parked times are all measured. The display shows either the running time or the time at which the stopwatch was last stopped.

The maximum time which can be measured is 99 hours 59 minutes. The time display shows seconds and tenths of a second for the first minute, then minutes and seconds, and hours and minutes after the first hour.

TEMP.

At ignition key position 1 and beyond, the outside (ambient) temperature is displayed when the button is pressed. At a temperature below 30 F (+3° C), a warning gong sounds. At the same time, the temperature function is selected automatically; the temperature is displayed and the ambient temperature flashes for 8 seconds.

The warning gong sounds again if the temperature has increased to 43 F (+6° C) at least once since the last warning signal, and **again** dropped below 37 F (+3° C).

CODE

When the code function is selected at ignition position 1, 4 segments flash in the display. A code number between 0000 and 9999 can now be input. Turn the ignition key to 2 to cancel the code. Turn the key to 0 to store the code number in the memory and activate the system; when an attempt is now made to start, the starter motor will turn but the engine will not start.

Memorize the code number!

To start the car or cancel the code, turn ignition key to position 1 or 2. The display will show code and 4 flashing segments. Input the code. The correct code will be automatically cancelled by starting engine or pressing the SET-RES button. (Note: If **neither** of these two steps are performed, the code will be retained in the memory for anti-theft protection).

Warning: If 3 incorrect codes are input consecutively, or 3 unsuccessful attempts are made to start the engine, a horn will sound for 30 seconds.

SET-RES

Press the button to SET-RESET:

- Average speed calculation
 - Average fuel consumption calculation;
- press to START/STOP:
- Stopwatch

If a code has been input to immobilize the car, the actual time will appear when the correct code number is input and the SET-RES button pressed.

Radio operation

If your BMW is equipped with a radio, you will receive an owner's instruction manual with the car's documents; this contains full details of **how to operate your car radio**.

The front-to-rear fader control distributes the sound between the front and rear speakers, while the balance between the left and right speakers is set at the radio.

The strength of the signal received by your car radio antenna, and thus the quality of the sound emerging from the loudspeakers depend on the position of the receiver and the height and direction of the antenna. These factors are relatively easy to take into account on a home radio receiver, but for a mobile radio set such as that in a car certain concessions have to be made. The position of the receiver is constantly changing and it is impossible to keep the antenna aligned with the direction of signal transmission.

Antenna

For the best reception quality, extend the antenna fully. For radio reception the bottom telescopic section must always be fully extended. The antenna should be cleaned regularly and protected against weather effects with antenna grease (this is particularly important for motor-driven antennas).

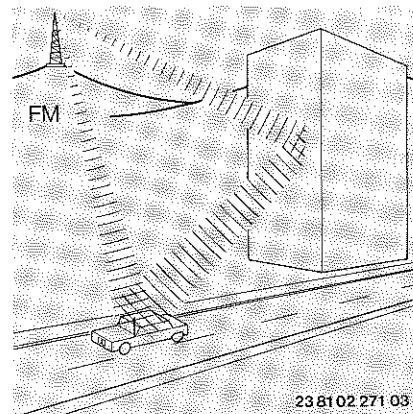

Climatic effects: fog, rain or snow can interfere with good radio reception.

As the **strength of sunlight** increases, long, medium and short wave reception is adversely affected. These wavebands can be best heard after dark, when the ionosphere reflects more of the transmitted signal back to earth.

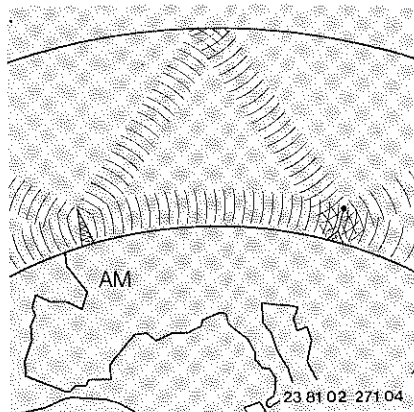

AM provides a larger or, in some cases, exceptionally wide reception range, since the signals are not only dispersed as **ground waves**, which cling to the curvature of the earth, but also as **space waves**, which are reflected off a layer in the ionosphere and bounce back to earth.

There are physical reasons why the quality of AM reception is not as good as on FM. However, long distance reception is good, particularly at night, so that a large number of stations can be received, though the station density is such that mutual interference often occurs.

The **FM** transmission system offers far better sound quality than **AM**. However, reception is limited to only a few stations at a time, since the radio waves are emitted in a **straight line** from the transmitter tower and thus cover an area not more than about 50 miles (80 km) in radius.

As the distance from the transmitter to the receiver increases, background noise becomes more of a problem, and finally the station can no longer be heard and is displaced by a more powerful one which the car is approaching. These too are natural factors which can only be avoided by re-tuning to a stronger signal.

Stereo, if transmitted in your area, can only be received on FM. As you move away from the transmitter, interference becomes noticeable more rapidly than on mono transmissions. In this case, switch to mono reception or tune to another station giving reliable stereo reception.

Fluttering noise is caused by signal fade, when the line-of-sight link between transmitter and receiver is blocked by large buildings or geographical features. A similar effect is sometimes heard when driving along a tree-lined road.

Hissing, sizzling and splashing noises: disturbance in this category occurs when reflected signals are picked up by the car radio a fraction of a second after the main signal, for instance from large buildings nearby. The sound level also fluctuates repeatedly.

Continuous high level of background noise: this normally indicates that the edge of the transmitter's zone has been reached, or the car has been driven into a "shadow" where no direct signals are received. The only alternative is to retune to a more powerful station.

Severe fade: this a phenomenon more often encountered on AM, and accompanied by distortion. It is caused by the superimposing of ground waves and airborne signals at the reception point.

Before and after starting

- Pull parking brake
- Turn off as many items of electrical equipment as possible to reduce the load on the battery, and on manual gearbox cars depress the clutch pedal.
- Always check first that the gear lever is in neutral before operating the starter.

Automatic transmission cars can only be started with the selector lever at **P** or **N**.

For cold starts, do not depress the accelerator pedal.

To start the engine turn the ignition key clockwise to position **3** and hold it there until the engine starts (but not longer than 20 seconds). When the key is released it will return automatically to position **2**.

The engine may run at a faster than usual idle speed while warming up.

If the starter has to be operated a second time, the ignition key must first be turned back from **2** to **1**. This interlock has been deliberately introduced to help ensure that the starter gear does not come into contact with the flywheel gear before the engine has ceased to revolve.

In very cold weather the first attempt to start engine should not last too long (max. app. 20 seconds) in order to limit battery discharge. If a second attempt is necessary, wait a short while (about 20 to 30 seconds), and then operate the starter again for a similar period.

The **fuel injection engine of your BMW** is equipped with automatic cold-starting and warming-up systems.

To **stop the engine**, turn the ignition key back to position 1.

Reductions in exhaust emissions and fuel consumption and the quality of the fuel used all influence the running characteristics of the engine.

Varying operating conditions are largely compensated by the measuring and control functions of the car's electronic system and by the high design and production standards of individual components. Individual systems such as electronic ignition and fuel-injection are also important in this respect.

Unusual engine and drive characteristics, for example when accelerating from a low engine speed, when combustion recommences after the overrun fuel shutoff has operated or at a low engine idle speed, are design features resulting from the compromise between demands for lower fuel consumption, ecologically more acceptable motoring and greater ride comfort, and not a sign that the vehicle needs attention.

Emission control system

Warning

The Emission Control System of your BMW is designed to remove pollutions of unleaded fuel only.

If leaded fuel is used – even only for a short period – the **oxygen sensor** and **catalytic converter** will be damaged and rendered inoperative.

To fulfil EPA Emission Standard the oxygen sensor and catalytic converter must be replaced after using fuel containing lead.

The catalytic converter is integrated into the exhaust system and installed below the vehicle's floor in the area of the front seats.

The oxygen sensor is necessary for the most efficient use of the catalytic converter.

After 30.000 or 50.000 miles the oxygen sensor must be replaced.

If unburned fuel reaches the catalyst, excessive temperatures and damage may result.

You should therefore avoid all operating conditions which are likely to cause unburned or insufficiently burned fuel reaching the catalyst, e. g.:

- unnecessarily prolonged operation of the starter motor
- frequent, repeated cold-starts
- allowing the engine to run with spark plug caps disconnected

If the ignition should misfire during a journey, please drive to the nearest BMW service station, using low engine speeds only.

Evaporative Emission Control System

This is a purge system consisting of a liquid-vapor separator, charcoal canister and purge lines which prevents gasoline vapors from escaping to the atmosphere.

Break-in

The engine of your BMW has not been governed in any way, so that there is no artificial restriction on its performance even when new. It is therefore up to you to ensure that the full operating life and potential economy are later achieved, and this is best done by adhering closely to the following **break-in rules**.

For the first 1200 miles (app. 2000 km), drive at varying road and engine speeds. Do not exceed the following engine speeds:

BMW 528e	3200 rpm
BMW 535i/S	4000 rpm

Note: do not exceed two-thirds of the permitted road speed in the 5th gear.

BMW M 5	5000 rpm
---------	----------

Maximum top speed 170 km/h/105 mph to 3000 miles (app. 5000 km), maximum top speed 220 km/h/136 mph. Do not use full throttle or the kick-down position of the accelerator pedal at all during this period.

Remember that the break-in rules apply to other mechanical assemblies such as the transmission or rear axle, and not just to the engine.

Should any such assembly be replaced at a later stage in the car's life, the break-in procedure must be repeated.

Hints on breaking-in brake pads:

As a means of achieving uniform wear patterns and a good friction coefficient on new pads, avoid repeated violent brake applications, especially from high speeds during the first 300 miles (app. 500 km), and also prolonged severe loads such as may occur when descending lengthy mountain passes. During the break-in period, refrain from subjecting the brakes to any form of endurance testing.

Brake pads, discs and drums require the distance stated above and the quoted operating conditions in order to seat properly and give smooth results and maximum wear later in the car's life.

Since the parking brake operates on an entirely separate brake system with its own drums, it must also be seated correctly.

If road surface, weather and traffic conditions permit, it is possible to achieve the desired effect by applying the parking brake lightly at about 25 mph (40 km/h), until definite resistance is felt. The lever should then be pulled up to the next notch and the car driven for about another 1300 ft (400 m) before the parking brake is completely released. This procedure will enable the parking brake to operate at maximum efficiency.

During the pre-delivery check or inspection your BMW dealer will seat the parking brake linings correctly.

You can repeat the process yourself provided that due care is exercised, at three-month intervals or whenever parking brake action becomes less effective.

Brake-in procedure for tires:

The production methods used in the tire industry result in brand-new tires having less than their designed adhesion at the road surface. Until full grip is available, and as a means of obtaining a good wear pattern you are recommended to drive with restraint for the first 200 miles (app. 300 km).

During the break-in period, a degree of **stiffness** may be noticed at the gear shift, in the steering and other controls and mechanical assemblies. This will disappear after a short period of use and should be regarded as part of the normal break-in process.

After 1200 miles (app. 2000 km) have been covered, you can **gradually increase** your road speeds to the **specified cruising and top speeds** of your car, assuming that general road and traffic conditions make such speeds possible.

Note:

Obey your local and state maximum speed limits.

Required fuel quality:

Your BMW is designed to operate with **unleaded fuel with an anti-knock index of 87 AKI**. This designation is comparable to Research Octane Number 91 RON. Only use fuels advertised to have adequate detergency and low alcohol content. Use of fuels with insufficient detergent and/or excess alcohol can cause driveability problems that necessitate cleaning intake valves and fuel injectors.

Traveling in foreign countries

Prior to using your BMW in a foreign country, check to ascertain if fuel of the required octane level is available to avoid engine damage.

Should unleaded fuel not be available in the foreign country in which you are traveling or intend to travel be aware that the use of leaded gasoline will render the oxygen sensor and catalytic converter of your BMW inoperative. As a result, the vehicle will not meet the emission requirements of the US and Canada and maximum fuel economy will not be obtained. It will, therefore, be necessary upon your return to the US or Canada for the fuel system to be purged of the leaded fuel and both the oxygen sensor and catalytic converter to be replaced in order for the vehicle to be legally operated in the US and Canada.

Your car's **fuel economy** is mainly dependent on your style of driving. High-speed driving, acceleration to the limit in all gears, violent cornering and sudden braking all take their toll, not only in terms of heavy fuel and oil consumption, but also faster wear of brakes, tires and all the engine parts.

In contrast to conventional engines, the BMW "eta" engine is specifically to operate more efficiently at low RPM.

By driving your 528e at lower engine speeds, maximum fuel economy can be achieved while retaining the performance characteristics of a low torque, high RPM engine.

To achieve the "eta" concept of maximum efficiency, observe the following rules:

- Improved driveability can be attained by driving at lower engine speeds and utilizing the existing engine torque.
- Shift up the next higher gear as soon as possible to maintain low engine speeds.
- Use the automatic cruise control when road conditions safely permit to avoid unnecessary acceleration and fuel consumption.

After driving for a while in dense city traffic or bumper to bumper, we recommend letting your engine "take a deep breath" by covering the next mile or two at engine speeds of 3000 rpm. This will help eliminate any carbon build-up in the cylinders.

It is not recommended to allow the engine to warm up at idling speed. Drive away at moderate engine speeds immediately after starting. However, if the outside temperature is exceptionally low the engine should be allowed to run at increased idle speed for about half a minute, to ensure proper circulation of the engine oil. Never run a cold engine at high speeds or its useful working life will be seriously reduced.

When **declutching**, always push the clutch pedal down fully; never drive with the foot resting on the pedal.

The **brake booster servo** on your BMW is charged up only when the engine is running. When the car is moved with the engine stopped, for instance when being towed, a much higher pedal pressure than usual will be needed to produce the anticipated braking effect.

Caution!

Do not drive with your foot resting on the brake pedal. "Riding" the brakes may result in abnormally high temperatures, lining wear and possible brake failure.

The economy of your BMW depends to a large extent on your driving style. Driving economically means watching the traffic well ahead and adapting to the conditions. Driving economically does not necessarily mean driving slowly.

Always keep the luggage compartment lid closed when on the move. This will prevent toxic exhaust gas from being drawn back into the car's interior. If you are carrying bulky items and cannot close the lid, it is a good precaution to close all the windows including the sliding roof if equipped and run the fresh air or heater blower at medium to high speed.

Do not put packages on the flat area behind the rear seat, as they may obscure vision and may become dangerous projectiles in the event of a sudden stop.

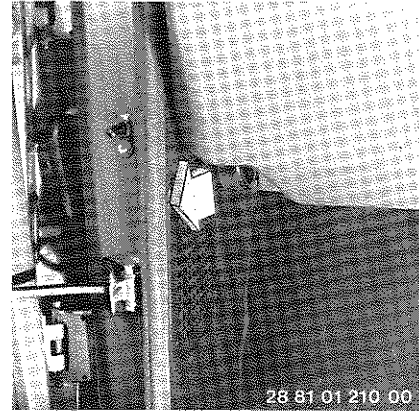

Hood

The hood is opened from inside the car by pulling the lever on the left side.

Warning:

When there is the danger of coming in contact with cables, when doing repair and maintenance work, especially in the engine compartment, always disconnect the battery.

Improper treatment of parts installed and materials used in the vehicle can endanger your personal safety. If you are not familiar with the pertinent safety rules, ask your BMW-dealer to perform the necessary work.

Digital Motor Electronics

This is a high performance ignition system, and any contact with ignition components when the engine is running is **highly dangerous**.

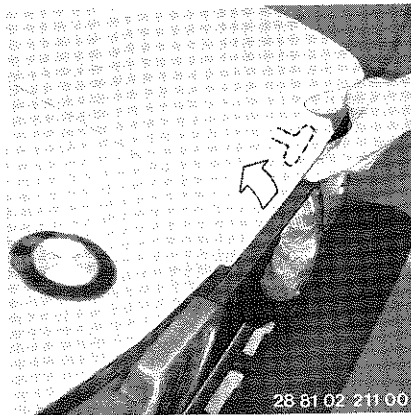

A Safety catch hook at the left front under the hood must be lifted and the hood can be opened.

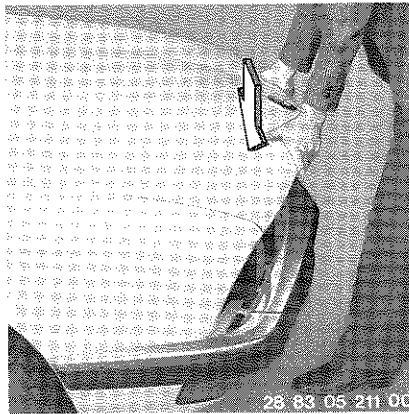

To close, lower the hood and press it down lightly in the center until the locks are heard to engage.

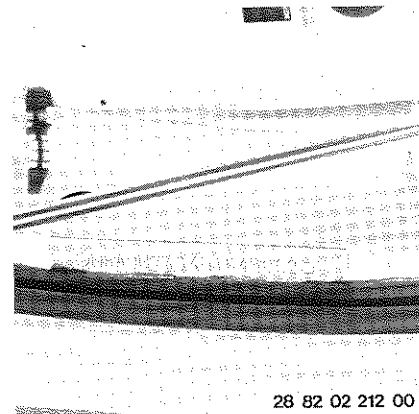

Chassis number

The **chassis number** can be used to check the identity of your car against your registration and licensing certificates.

The chassis number is stamped into the right inner fender panel adjacent to the coil spring tower as shown below and also on an adhesive label located inside the left front door opening.

The number is also stamped on a metal strip that is fastened to the instrument panel adjacent to the middle of the windshield.

As an effort to deter theft the number is also stamped on body components, engine and transmission.

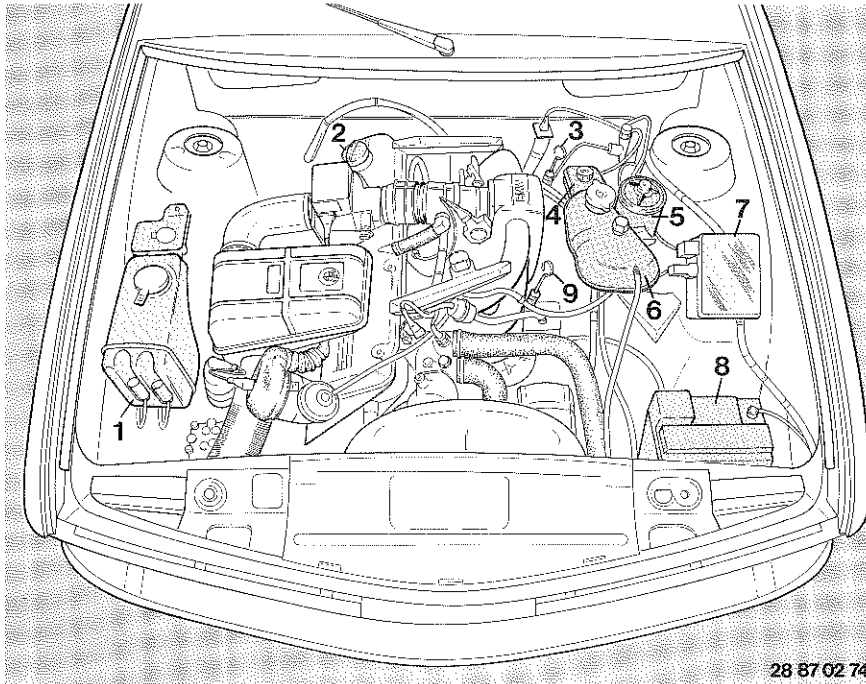

28 87 02 74

The engine compartment at a glance

- | | |
|---|-----------------------------------|
| 1 – Fluid tank for windshield washer | 5 – Fluid tank for power steering |
| 2 – Engine oil filler | 6 – Coolant tank |
| 3 – Dipstick for automatic transmission | 7 – Fuse box |
| 4 – Fluid tank for brake and clutch hydraulic | 8 – Battery |
| | 9 – Dipstick for engine oil |

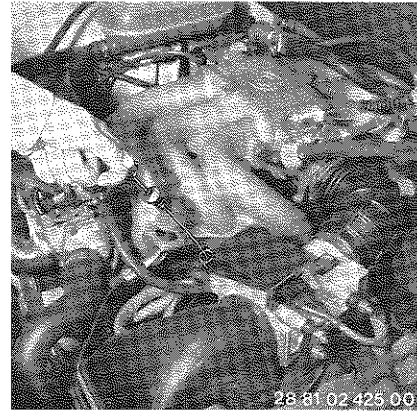

28 81 02 425 00

Engine oil consumption

like fuel consumption, depends on the way in which the car is driven and the operating conditions.

Engine oil level check

We recommend that you check the engine oil level regularly, for instance whenever you buy fuel. If necessary, add fresh oil to the filler on the engine's rocker cover. Do not fill beyond the upper mark on the dipstick.

The most accurate oil level reading will be obtained with the car standing on a level surface and the oil cold (before the engine is started), or after allowing the oil to drain back into the sump for a short period (if the engine has already been run).

Make sure that the dipstick is inserted fully into the tube on the engine block.

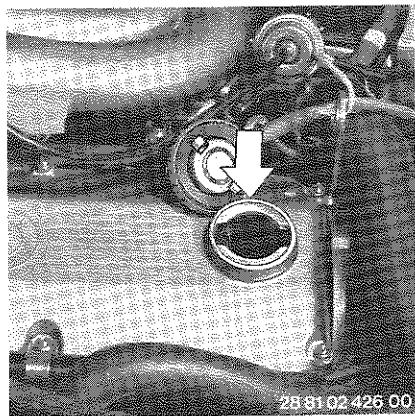

28-81 02 426 00

Adding fresh engine oil

The quantity of oil represented by the space between the two marks on the dipstick is app. 1 liter (1.1 US quarts, 1.75 Imp. pints).

Adding too much oil serves no useful purpose and may even harm the engine. Since this excess oil will tend to be burned off within a short time, it may create the impression that oil consumption is heavier than usual.

The best procedure is to add fresh oil only when the level has dropped almost to the lower mark on the dipstick. However do not allow the level to fall below the minimum-level mark.

BMW engines are designed to require **no oil additives** if one of today's highly advanced brand-name lubricating oils is used: Using additives could cause engine damage. The same applies to the oil for the manual gearbox or automatic transmission, final drive and power steering.

Engine oil specifications

Although API SE grade oil are approved for use in your BMW, API SF grades are **highly recommended** due to their increased oxidation stability, wear protection, and detergent properties. The increased level of protection available by the use of SF grade oil will help you to attain the maximum amount of engine service engineered into your BMW.

The chart indicates the SAE grades to be used depending on the predominant air temperature.

The temperature set by the SAE grades may remain under or exceed the limit for a short period.

Heavy duty engine oil may be used in the manual gearbox if the car is driven in extremely cold climates. Contact your BMW dealer for details.

BMW M 5

Use only approved oil grades to API SF with a viscosity of SAE 15 W-40 or 15 W-50.

Low friction lubricants are not permitted.

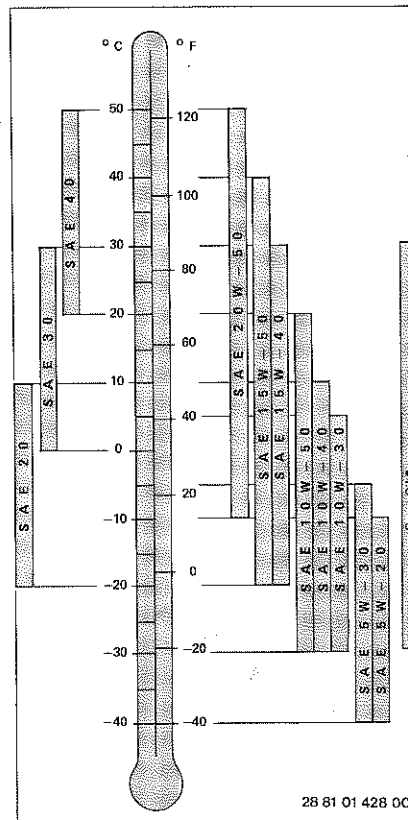

28 81 01 428 00

* Special oils individually approved by BMW (low friction lubricants). Contact your BMW dealer for details.

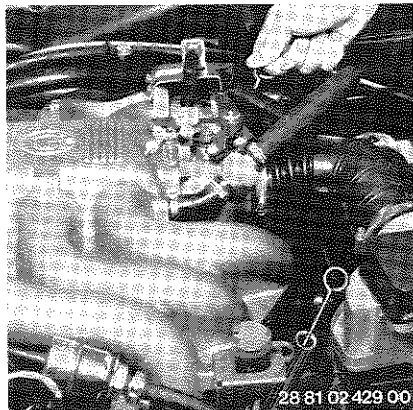

28 81 02 429 00

Automatic transmission – Oil level check

Check oil (ATF) level in the automatic transmission regularly, e. g. when engine oil level is checked.

The car should be standing on a flat, level surface, with the parking brake applied. The engine should be at **normal operating temperature** (80° C/176° F). Select P or N at the transmission selector lever, and allow the engine to idle.

Pull out the transmission dipstick, wipe with a lint-free cloth and push back in to measure the oil level. It should be between the two dipstick marks.

The quantity of oil represented by the distance between the two dipstick marks when the transmission is at normal operating temperature is app. 0.45 Imp. pint, 0.30 US quart (0.25 liter).

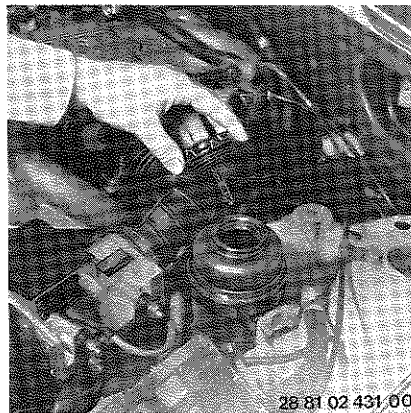

28 81 02 431 00

Power steering – oil level check

(BMW 528e)

With the engine stopped, unscrew the oil reservoir cover. With the cover resting in position, the oil lever should show between the dipstick markings. Add oil (ATF) if necessary. After this, **run the engine** and top up the oil if necessary.

When the engine is stopped, the oil level should not rise by more than approx. 5 mm or 0.2 in above the "MAX" mark. Screw the cover back on.

(BMW 535i/S, M 5)

With the engine stopped, remove the wing nut and take off the fluid reservoir cover. Apply the foot brake several times until the oil level ceases to rise or the pedal becomes noticeably more difficult

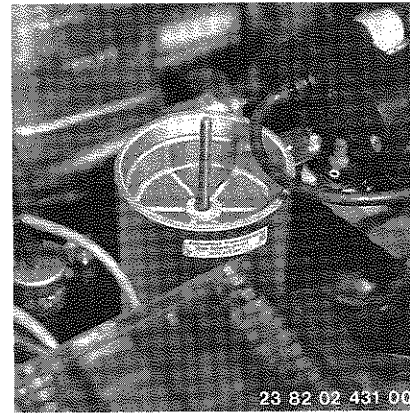

23 82 02 431 00

to press down; about 10 brake applications will be necessary. The oil level must rise to app. 0.4 in (10 mm) below the upper rim of the reservoir. Correct if necessary by adding more oil (ATF) of the correct grade.

Attach the cover to the reservoir and tighten the wing nut. Make sure that the cover is correctly seated, and there are no leaks in the power steering circuit.

Steering stiff to turn towards right and left lock; whining noise audible:

Too little oil in system. Check level and if necessary inspect the power steering circuit for leaks or damage.

Loose V-belt. Adjust to correct tension. If belt is damaged, replace it.

A slightly higher effort is needed to turn the steering wheel when the power steering is defective.

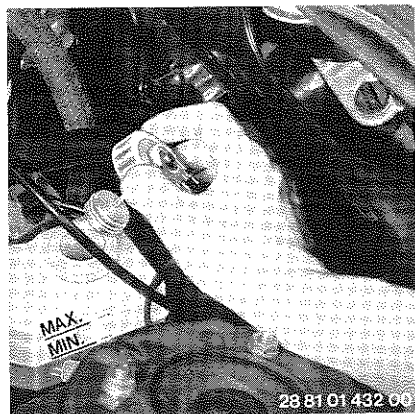

Brake and clutch hydraulic Fluid level check

The fluid is hygroscopic by nature, that means it will tend to absorb moisture from the atmosphere over a period. In order to ensure that the brake system remains fully operational, **the brake and clutch hydraulic fluid must be replaced once a year.**

Top up to the "MAX" mark.

Use only DOT 4 brake fluid.

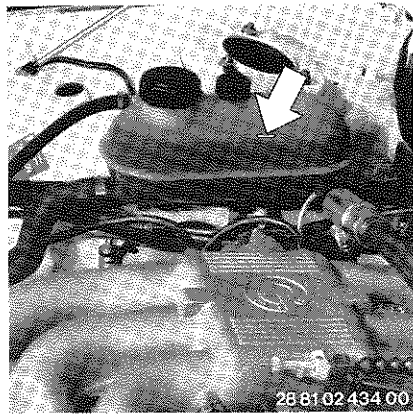

Coolant level check

The transparent coolant tank permits coolant level to be checked without removing the cap.

Warning:

Open the radiator cap only when the engine has cooled down and the coolant needle is on the lower third of the scale, or else hot water or steam may escape and cause you to be scalded.

Turn the cap slightly counterclockwise to allow excess pressure to escape, then remove completely.

Overfilling will dilute the additives in the coolant, which will escape through the overflow pipe and no longer possess the correct antifreeze and corrosion inhibitor concentration.

Never add water if the cooling system is still hot and coolant has been lost: allow the engine to cool down.

Apart from regular checks on coolant level, antifreeze concentration (at least 50 % = -35°F = -37°C year round) and the condition of hoses and hose clamps, we recommend that the cooling system be drained and refilled **every two years.** At the same time, check that the filler cap seals properly and that the pressure relief and vacuum equalizing valves are in good working condition.

The fluid of the cooling system needs no further addition agent. Use only factory approved fluid to prevent damage.

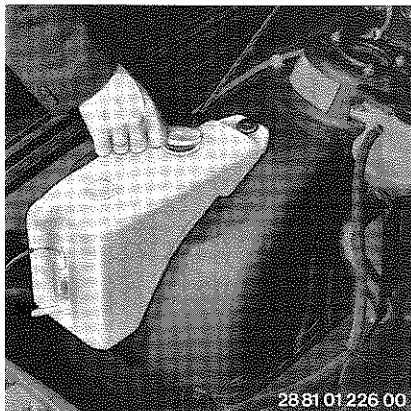

28 81 01 226 00

Windshield washer fluid tank

The **fluid tank** holds approx. 3.0 US quarts/3 liters/5.2 Imp. pints and is located at the front right of the engine compartment.

Warning: do not run the automatic windshield washer if the fluid tank is empty.

In cold weather, the windshield washer system can be kept fully operational by adding windshield washer antifreeze in the proportions recommended by the manufacturer.

Windshield washer jets

If the stream of water fails to strike the center of the area covered by the wiper on that side, the jet can be carefully repositioned with a fine needle to redirect the water stream.

The windscreen washer jet heating comes on automatically at ignition switch position 2.

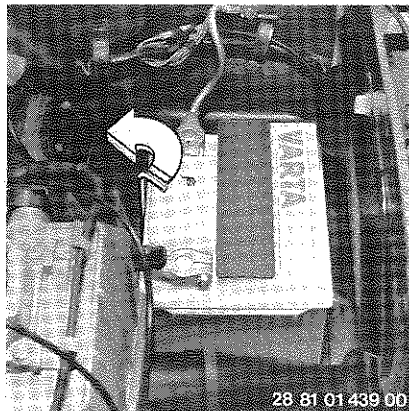

28 81 01 439 00

Battery

Your BMW's battery is maintenance free to DIN standard 43 539 Part 2 and the electrolyte added initially should normally last for the life of the battery. If the level is too low in any of the cells, for instance after spending long periods in a hot climate, top up with distilled water (not acid).

The battery is located in the engine compartment on the left. On the BMW M 5, the battery is in the luggage compartment and can be reached by removing the trim.

Take off the cover and unscrew the 6 cell plugs. The acid level should be about 0.2 in or 5 mm above the upper edges of the plates or at the mark visible in the filler opening depending on battery type.

Keep the upper part of the battery clean and dry.

To remove or install the battery, loosen or tighten the toggle screw and retaining bar.

Important notes:

1. Acid or lead oxide from the battery terminals must never be allowed to contact the eyes, skin or clothing. Rinse off immediately with clean water, and consult a physician if necessary.
2. Never short-circuit the battery poles; this will cause severe overheating and could lead to the battery case bursting.
3. When the cell plugs have been removed, never bring an open flame near the battery or cause any sparks in the vicinity. This could lead to an explosion.
4. Never detach the battery leads when the engine is running, or else an overvoltage will occur and damage the car's electronic equipment beyond repair.
5. To recharge the battery without removing it from the car, the engine must be stopped and both battery leads disconnected.
6. Disconnect the negative lead from the battery before attempting any work on the car's electrical system, to avoid the risk of a short-circuit.
7. If the vehicle is to be laid up out of use for a fairly long period – see page 59 – remove the battery, have it charged and stored in a cool place with no risk of frost damage. The battery must be recharged after not more than 6 months, or it will discharge completely and cannot then be re-used on the vehicle.
8. To remove the battery, first disconnect the negative lead, then the positive lead. Unscrew the battery retaining bar. When installing, first secure the battery with the retaining bar, then connect the positive lead and finally the negative lead.

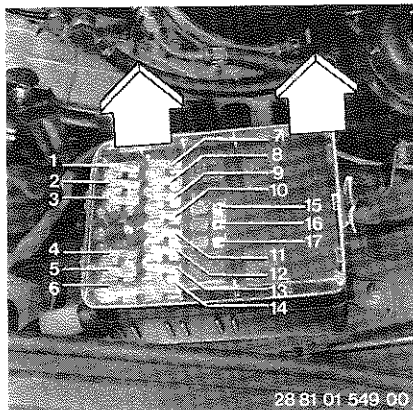

Fuses

If any electrical equipment on your car should fail, first check the fuses.

A blown fuse can be identified by the melted metal strip inside the fuse holders. Pull the blown fuse out, trace and rectify the cause of the failure, then insert a new fuse of the correct rating.

The **fuse box** with spare fuses and relays is located on the left wheel arch inside the engine compartment.

Caution:

Never replace blown fuses with wire or attempt to repair them in any way (fire hazard).

An accessory connector in the engine compartment close to the fuse box provides connections from terminal 15 and 30.

Ratings in Amperes, equipment supplied.

1. Electrical fuel pump
2. Low beam right
3. Low beam left
4. Cigarette lighter, power antenna, heated seat, parked car heater
5. Hazard warning flashers, interior lights, glove box, luggage compartment light, clock, central locking system, antitheft-protection on-board computer, service indicator, door lock heating, check control
6. Instruments, tachometer, power outside mirrors, on-board computer, central warning light, check control, fuel consumption indicator, service indicator, cruise control, power windows, backup light, lever positions lights for autom. transmission,
7. High beam right
8. High beam left
9. Side lights right, sidemarker right, rear light right, instrument panel lights, licence plate lights
10. Side lights left, sidemarker left, rear light left
11. Turn signal, windshield wiper and washer, horn
12. Stop light, radio memory, check control
13. Rear window defroster, power sliding roof
14. Blower air conditioning
15. Left fog light
16. Right fog light
17. Supplementary fan

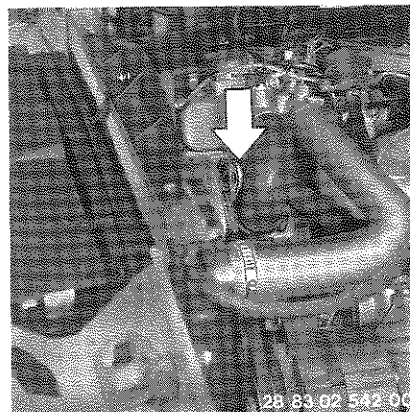

Jump starting

If the battery is run down, the engine can still be started by running 'jumper' cables to the battery from a second vehicle.

1. Check that the other vehicle has a 12-volt electrical system and a battery of approximately the same capacity in A/h.
2. The dead battery has to remain connected.
3. Do not allow the two vehicles to touch another, or a short circuit may be the result.
4. First connect the positive terminals of the car's batteries together. Then connect the other jumper cable to the negative post of the second car's battery and to the lifting bracket or engine block of your car, as far away from the battery as possible.

Caution! If connections deviate from that described in the foregoing, damage to both charging systems or even serious personal injury could result.

BMW M 5: On this model the positive terminal of the jumper cable can be connected in the engine compartment on the right side of the heater bulkhead. Then connect the second jumper cable to the negative post of the second car's battery and to the lifting bracket or engine block of your car.

- Run the other car's engine at a steady 2000 rpm and then start your engine in the usual manner.

Before disconnecting the jumper cables make certain that the engine is at idle speed, switch on headlight, blower and rear window defroster to avoid damage to car's electrical system. Carefully disconnect the jumper cables, starting with the negative terminal.

Warning: Ignition system

This is a high-performance ignition system and any contact with live components when the engine is running could lead to a fatal electric shock.

When attempting any repair or checking procedure make sure there is no loose or hanging clothing and avoid contacting the electrical system or rotating fans and belts.

Tool kit

The **tool kit** is in a rack under the luggage compartment lid which swings down when the retaining screw is undone.

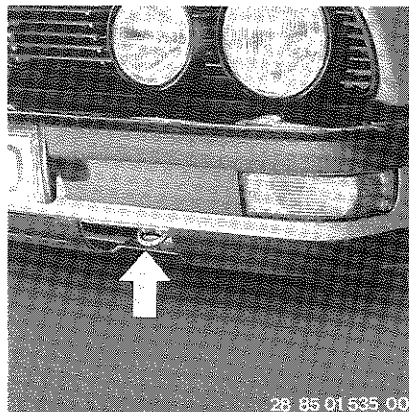

Tow-starting

Switch on the ignition, select 3rd gear and disengage the clutch.

Switch on the hazard warning flashers if required by law.

When the car is moving at a fair speed, engage the clutch. After the engine has started, declutch again and allow the engine to idle. Switch off the hazard warning flashers when no longer needed. The cause of poor starting should be investigated and put right by the nearest BMW dealer.

Tow starts – BMW automatic models

The design of the automatic transmission makes it **impossible** to start the engine by pushing or towing the car.

Towing away – BMW automatic models

If the car has to be towed away, the ignition switch must be put to position 1 and the selector lever must be at **N** = neutral.

Towing speed should not exceed 30 mph or 50 km/h and the towing distance should be limited to 25–30 miles or 40–50 km. To tow an automatic transmission car more than 30 miles or 50 km add 1.05 US quarts/1 liter/1.8 Imp pints of ATF (automatic transmission fluid) to the contents of the transmission, or remove the drive shaft. After the car has been repaired, do not forget to reduce the fluid level in the transmission to normal.

Towing facilities

Towing eyes are situated at the left and right front side and at the right back side.

Use nylon towropes or straps which are sufficiently resilient to protect both vehicles against sudden jerking. Alternatively, a towbar may be used.

When using a towbar, both cars' towing eyes must be on the same side.

If the towbar runs at an angle, note the following:

- the amount of free movement between the cars is limited on bends
- the angle of the towbar gives rise to lateral forces (particularly dangerous on slippery road surfaces)
- do not attempt to steer the car being towed along the same line as the towing vehicle
- there is a danger of the towed car jack-knifing when the towing vehicle is braked.

Towing away

If the vehicle has to be towed away, turn the ignition key to position 1 so that the brake lights and turn indicators operate and the horn and wipers can be used.

Switch on the hazard warning flashers if required by law.

If the electrical system is out of action, the towed car must be identified (for instance by a notice or by placing the warning triangle in the rear window) so that following vehicles are warned.

In case of engine failure and when the car is being towed, the power assistance for the brakes, and steering where applicable, is no longer effective. Increased effort will be required to operate the affected systems.

If you wish to assist another driver by towing his vehicle with your BMW, make quite sure that the broken-down vehicle's weight does not exceed that of your own car.

PLEASE COMPLY WITH APPLICABLE STATE TOWING LAWS

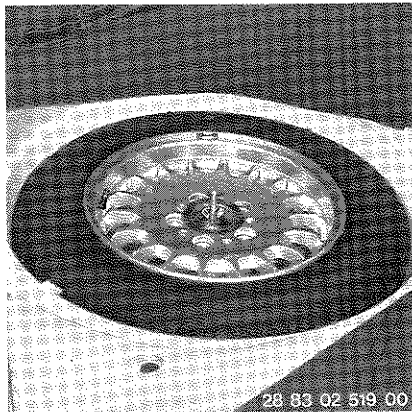

Wheel changing

Flat tires are fortunately a rare event nowadays. Should you have the misfortune to suffer a puncture, drive the car away from the main traffic stream and apply the parking brake. Comply with local regulations concerning the protection of broken-down vehicles by switching on the hazard warning flashers and setting up a warning triangle, flashing signal lamp etc. at a sufficient distance away from the car.

The **spare tire** is located in a recess under the carpet of the luggage compartment floor.

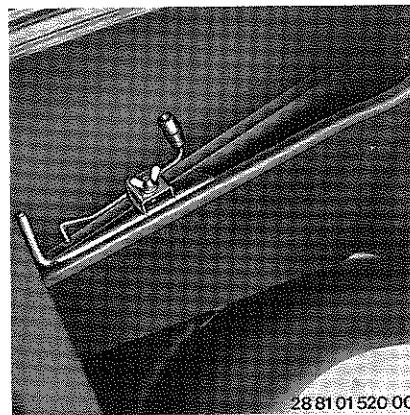

Jack and wheel stud wrench

The jack and wheel stud wrench are housed in a compartment on the left side of the luggage compartment. The jack can be lifted out after removing the wing nut. To prevent noise when the jack is stored in the luggage compartment again, it must be retracted fully and secured with the wing nut in its original position.

Warning: place the **wheel chock** on the opposite rear wheel to prevent the car from moving when it is raised on the jack (this is necessary on account of the parking brake design).

Pull on the parking brake

Loosen the wheel studs before lifting the car. Pull off the hub cap. On alloy wheels, press out the hub cap by hand from the front after removing the wheel.

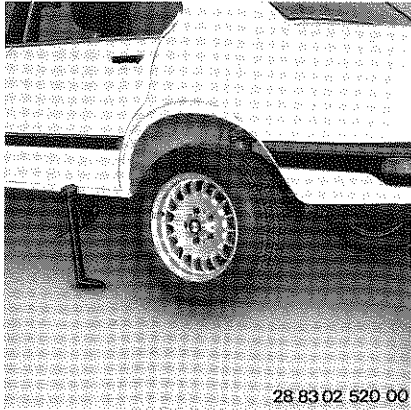

28 83 02 520 00

Attach the jack to one of the **four pickup points** provided on the body (the one nearest the punctured wheel) and jack up the car until the wheel is well clear of the ground.

Warning: never work underneath a jacked-up vehicle.

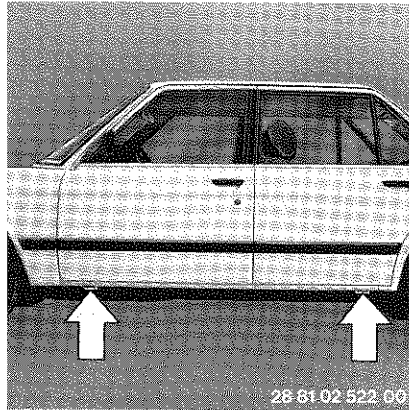

28 81 02 522 00

Tire repairs should always be entrusted to a BMW dealer or a specialist tire dealer capable of examining the tire to determine the full extent of possibly concealed damage.

Important: When removing or replacing tubeless tires, the rubber valve must also be replaced as a safety precaution.

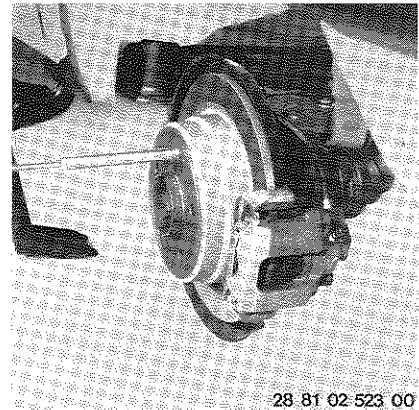

28 81 02 523 00

Unscrew the wheel studs and change the wheels. To fit the spare wheel, insert the centering pin into one of the holes, put the wheel on to the pin, screw in one wheel stud, then remove the centering pin. Screw in the remaining wheel studs and tighten them uniformly.

Lower the car from the jack, tighten the wheel studs finally in a crosswise pattern (first one stud, then the other on the opposite of the hub) and have the tightening torques checked at the earliest opportunity. (110 Nm/81 ft/lb with a calibrated torque wrench.) If a new tire (or the spare tire) is installed for the first time, have tightening torques of studs checked after app. 600 miles (1000 km).

Have the flat tire repaired and rebalanced as soon as possible.

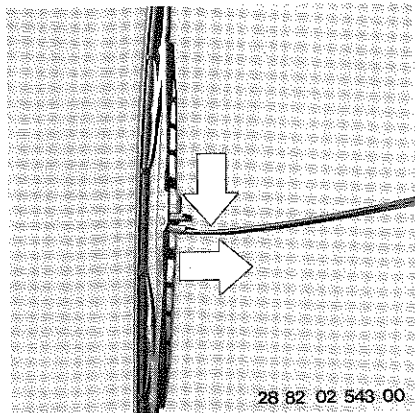

28 82 02 543 00

Wiper blades

To remove a **wiper blade**, swing the arm away from the windshield. Press the retaining spring and pull the blade from the arm.

Caution!

Do not manually move the wiper arms across the windshield because you may damage the wiper arms or pivots.

The complete **wiper arm** can be pulled off after folding up the plastic cap and loosening the retaining nut.

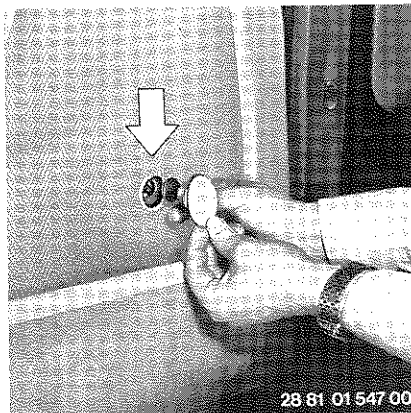

28 81 01 547 00

Electrical front windows

If there is a problem with the electrical system, **the front windows can be opened by hand** in emergency.

The necessary tools (adapter, allen key, handle, spark plug wrench and bar) are included in the car's toolkit.

- Remove the sealing cap from the side trim.

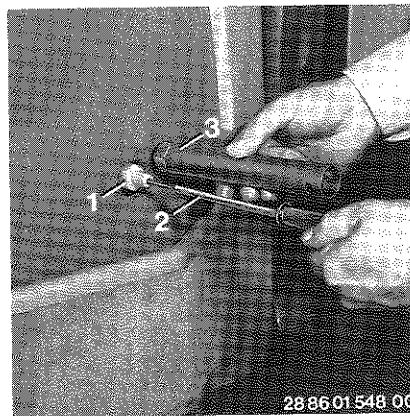

28 86 01 548 00

- Attach handle (from screwdriver) to allen key (2) and fit to adapter (1).
- Turn the allen screw clockwise until it cannot be moved any further.
- Place the spark plug wrench (3) on the adapter and turn in the required direction with the bar.
- Unscrew the allen screw counter-clockwise by app. 2 turns. This will retain the glass in the position chosen.

The window may be opened and closed by hand as often as necessary until repaired.

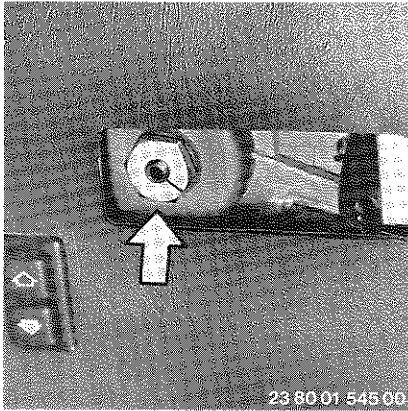

23 60 01 545 00

Sliding/vent sun roof

If the electric motor drive of the sliding/vent sun roof should fail, the roof can be operated manually as follows: (Using tools supplied in the luggage compartment lid).

- Remove protection cap,
- Loosen nut with spark plug wrench and adjust sliding roof with an allen key to desired position.



34 61 02 562 00

Bulb changing

When changing bulbs or performing any other minor jobs on the electrical system, avoid short circuits by leaving the item concerned switched off or disconnecting the negative lead at the battery.

When replacing bulbs always use a clean cloth to keep the glass free of sediments.

Headlight

The headlight inserts for the **low beams** are in the two outer lamps.

To change headlight inserts for the low beams, first disconnect battery (–) ground cable. Remove ornamental grilles. Loosen the three screws on the clamping ring and pull back the cable connector.

The headlight inserts for the **high beams** – i. e. the inner lamps – must be replaced in the same way.



48 11 02 552 01

When replacing headlight inserts make sure that the beam alignment screws are not twisted.

As correct headlight adjustment is of particular importance in view of traffic safety, the headlights should be adjusted by a specialist workshop using the proper beam-setting equipment.

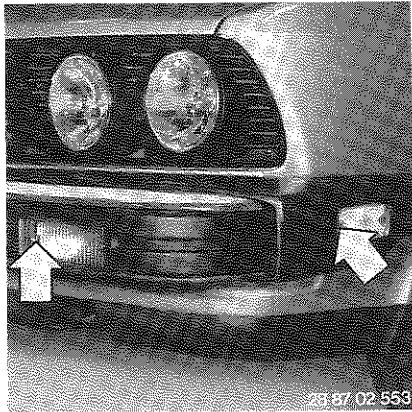

Side marker lights, parking lights and front turning lamps

Unscrew the Philips head screws holding the plastic lens, and remove lens. The 21/5 W spherical bulb must be pressed in slightly and turned.

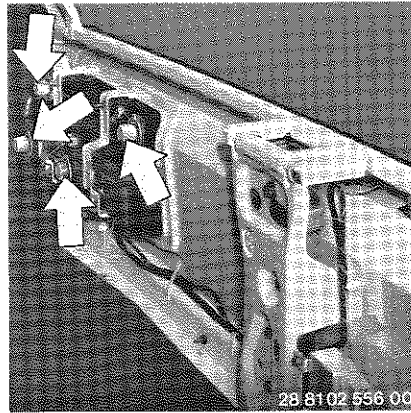

Rear light

Open the luggage compartment, remove the rear lining panel and lift off the lens assembly. Remove the defective bulb from its holder and insert a new bulb.

Turn indicator – 21 Watt spherical bulb.

Rear light – 5 Watt spherical bulb.

Brake (stop) light – 21 Watt spherical bulb.

Reversing (backup) light – 21 Watt spherical bulb.



Rear lights

They are arranged as follows:

- | | |
|------------------------------|----------|
| 1 – Reversing (backup) light | (white) |
| 2 – Turn indicator | (yellow) |
| 3 – Brake (stop) light | (red) |
| 4 – Rear light and reflector | (red) |



Rear side marker

A rear side marker light is installed on both sides of your car. The side marker lights are equipped with 4 Watt bulbs. To replace, loosen screws and remove plastic lenses.

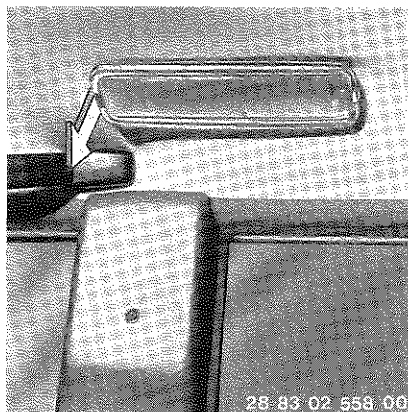

Interior light

After pulling out the interior light assembly the 10 Watt tubular type bulb becomes accessible.

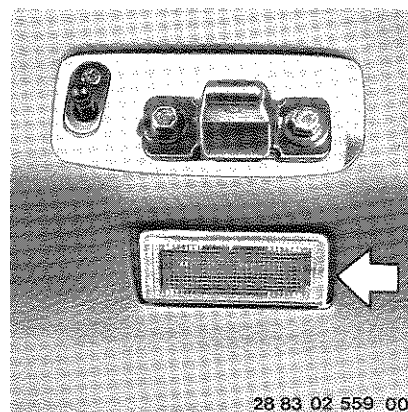

Luggage compartment light

The 5 Watt tubular-type bulb can be reached after pulling out the luggage compartment light assembly.

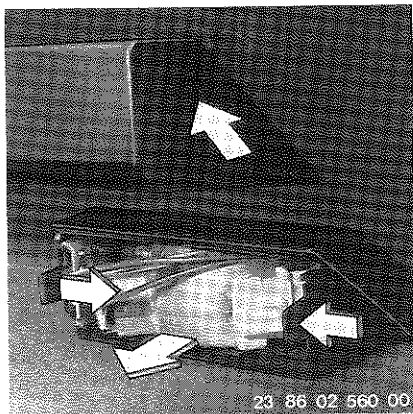

Center brake (stop) light

Pull off the rear cover (arrow).

To remove the reflector press latches and pull assembly back.

Replace 21 Watt bulb.

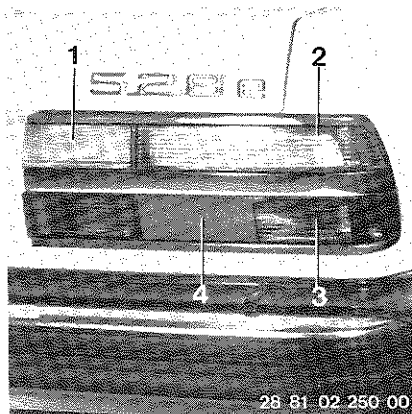

License plate light

Remove the two Philips head screws and take off the lens frame with rubber seal. The contact blades for the 5 Watt tubular type bulb must make good spring contact and the metal surfaces must be clean. If necessary, clean and bend in the contact blades.

Storage out of use

If the car is to be laid up out of use for more than three months, we recommend that the following maintenance work be performed by a BMW dealer or at any qualified workshop in order to prevent deterioration during the storage period.

1. Wash the body and the underside of the car, clean the interior and finally polish the paintwork and clean chrome-plated parts. Clean rubber seals on lids and doors and rub them with talcum or glycerin. If necessary, have the undercoating checked or repaired in accordance with BMW factory recommendations.
2. Change the engine oil and replace the oil filter element while the engine is at normal operating temperature. As an additional anti-corrosion measure, a corrosion inhibitor can be added to the engine oil as specified by the supplier.
3. Check coolant level and concentration, and top up if necessary.
4. Check acid level in battery cells and top up with distilled water if necessary.
5. Drain the windshield washer fluid tank and lines.
6. The fuel tank should be filled, to prevent corrosion caused by moisture condensate.
7. Increase tire pressure to 4 bars or 60 lb/in².

Immediately before the car is taken out of use, while driving apply the foot brake and the parking brake until warm, so that the pads and linings are dry and the brake discs and drums will not corrode.

Store the car in a dry, well-ventilated space. Engage reverse gear. Do not apply

the parking brake. If necessary, chock a wheel to prevent rolling away.

Disconnect the negative lead from the battery. If there is any risk of frost, remove the battery and store in a warmer place. The battery must be recharged at least every 6 months or it will become unsuitable for further use.

The air conditioning must be run briefly at least once a month at an ambient temperature of at least 41° F (5° C) (this is particularly important in the cold season of the year), or else the compressor shaft seals may dry out and permit refrigerant to leak. The engine should run for this purpose until it reaches its normal operating temperature (coolant thermometer needle approximately midway between the two colored zones). This will avoid condensate formation and the risk of internal engine corrosion. If the car is not equipped with air conditioning, do not run the engine during the storage period.

Warning:

If the engine needs to be run for the above reasons, do so only in a well ventilated space to avoid exhaust fumes.

Restoring car to use

First recharge the battery, or replace it if necessary. The following maintenance work should then be carried out.

1. Change the engine oil and the oil filter element while the engine is at normal operating temperature.
2. Refill the windshield washer fluid tank, including antifreeze if necessary.
3. Restore tire pressures to the correct values.

Winter operation

The winter months often bring with them severe changes in the weather, and you must not only adopt a correspondingly careful attitude to driving but also take a few precautions to ensure that your BMW comes through the winter months reliably and without breakdowns.

On winter roads, tire grip is often very poor, and the driver must remember that braking distances are much greater than usual in many situations.

Before the cold season of the year commences, you are recommended to take your car to a BMW dealer, or any other qualified service establishment for the necessary winter preparations to be carried out.

Note in addition the **engine oil specifications** for winter operation.

Do not wait until the next routine oil change to fill the engine with wintergrade oil if the weather turns cold suddenly.

Apart from checking oil levels during a BMW Inspection, no special winter operating precautions are needed on the manual gearbox/automatic transmission power steering or hydraulic brake system.

The coolant on your BMW already contains a **long-term antifreeze and corrosion inhibitor**. The concentration must be kept at 50 % all the year round. This will provide antifreeze protection down to app. -37° C (-34° F).

Use only reputable brand ethylene glycol antifreeze with corrosion inhibitors that are compatible with aluminium radiators.

Replace the coolant every 2 years. Check antifreeze concentration before and during the cold season. At the same time, inspect the cooling system for leaks and any coolant hoses which may have become porous or brittle.

Engine temperature is regulated by the coolant thermostat according to outside temperature and engine load. For this reason, **no radiator cover should be fitted** or the radiator grille blocked off.

The engine will only start reliably if the **battery** is fully charged. Remember, though, that a cold battery is less efficient, yet the demands made on it are more severe than in warm weather, with less driving after dark.

To prevent **rubber seals** on doors and lids from freezing, treat them with a rubber-care product or silicone spray.

The car's **paintwork**, as well as **chrome plating** of polished metal parts, should be protected before and during the winter months with suitable bodywork care products.

Have your BMW's brakes checked as a precaution before and after each winter driving period. This work can usually be combined with whatever maintenance routine happens to fall due.

Winter tires

If winter tires (radial-ply tires with special winter tread pattern) are installed, they must in the interests of good directional stability and steering control be of the same make and tread pattern **on all four wheels.**

Your BMW dealer will be glad to advise you on selecting the right winter tire for the anticipated operating conditions.

Also observe the specified **tire inflation pressures** and have the wheels balanced whenever you change a tire or wheel.

Always adhere strictly to the maximum road speeds specified for your winter tires.

When tread depth has worn to less than 4 mm (0.16 in), tires become much less effective in winter, and should be replaced as a safety precaution.

Use only snow chains according to SAE J 1232 classification "S". The snow chains may be used on drive wheels (rear) only.

Warning:

Even if your local speed limit for cars with snow chains is higher, or there is no official speed limit, do not exceed 31 miles/h (50 km/h).

Winter driving hints

Driving when wearing ski boots is definitely not recommended, as it is then difficult to operate the pedals sensitively or to avoid touching the wrong pedal accidentally.

After starting a cold engine particularly at temperatures below +5° F, (-15° C), the gear shift may be stiff and the car's suspension may not respond smoothly for the first few minutes of a journey, and other items of equipment may prove noisier in operation. This is unavoidable while the oil is still thick and viscous.

Before starting the journey, remove ice and snow from the windows, outside mirrors and light lenses. After a heavy fall of snow, remove snow from the roof, engine and luggage compartments to prevent it from blowing off and obscuring your vision. Clear snow from the air entry grilles for the heater/ventilating system below the windshield, so that airflow is not impeded.

Before getting into the car, try to remove slush, snow and ice from your shoes to avoid the risk of slipping off the pedals.

When **driving on slippery surfaces**, depress the accelerator smoothly and slowly, and shift up to a higher gear quite early to avoid the use of high engine speeds. Keep a particularly large safety margin between your car and the one in front. Select the next-lower gear when conditions permit before reaching an uphill or downhill gradient.

To improve traction on icy or snow covered roads and in hilly country when the car is otherwise unladen, 110 lb (50 kg) of ballast can be carried in the luggage compartment. Make sure that the ballast is secure and cannot slip.

In cold weather we recommend carrying the following items in case of emergency:

- a quantity of **sand** for traction on ice covered slopes
- a **shovel** to extricate the car from snowdrifts
- a **plank** to act as a support for the car's jack
- a **brush and ice scraper** to clean the windows and body panels if they are covered with snow or ice.

Useful information on disc brakes

Your BMW is equipped with power brakes to reduce the required pedal effort utilizing a brake booster servo. Should the engine stop for any reason, several brake applications with power assist will still be available due to a reserve designed into the system.

When the vehicle is moved with the engine stopped and the power assist reserve exhausted, for example, when towing, a higher pedal pressure will be needed to produce an equivalent braking torque.

The engine's pumping loss due to operating the engine with closed throttle and frictional loss can be utilized effectively to brake the vehicle by selecting a lower gear up to the rpm limit of the engine. This technique is commonly referred to as "engine braking".

Warning:

Never coast with the clutch pedal depressed, the shift lever in neutral, or the ignition switched off.

To assure proper seating of the brake pads to the discs to maximize braking effectiveness, it is essential to observe the break-in instructions for the braking system of a new vehicle or whenever new brake discs and/or pads are installed. See break-in rules.

BMW brake components, wheels and tires have been carefully selected and engineered to provide a high degree of control under severe and diverse operating conditions. It is therefore recommended that BMW replacement parts be used and brake components, wheels and tires not be altered to maintain the carefully bal-

anced braking and handling characteristics designed into your vehicle.

A disc brake system offers optimum braking efficiency, smooth response, and a high load capacity. The high temperatures which occur during brake applications, e. g. on mountain passes when driving quickly, necessitate a maximum degree of cooling which is provided by the air flow generated by the peripheral speed of the brake discs and wheel design. Altering vehicle design could inhibit air flow and impair braking effectiveness.

A slight rust film may develop on any disc brake equipped vehicle parked for an extended period of time. The rust film will be substantially less or non-existent on the brake disc surface protected by the brake pads; therefore, after such periods of extended parking, the driver may notice a slight pulsation during braking. This pulsation will disappear as the brakes are again used. Slightly heavier than normal applications during braking will accelerate the rust removal process.

Your BMW is equipped with corundum coated brake pads. This slight abrasive coating helps the brake pads remove minor surface rust on the discs during break-in for approximately 200 miles. During such time, a higher than normal "disc-brake squeal" (a very high pitched noise) may be apparent.

Keeping disc brakes in trim

In wet conditions or during rainfall it is advisable to apply the brakes briefly with light pedal pressure every few miles. The heat generated in this way keeps the discs and pads dry for a certain period.

Before you park the car after driving through the rain, and especially if salt has been spread on the roads, lightly brake the car to a standstill so that the brake discs remain dry and cannot corrode easily.

The most effective braking action is achieved not with locked wheels, but when the wheels are still just turning.

Locking the wheels can be dangerous, as locked front wheels can no longer be steered, and locked rear wheels cause the car to slide sideways or spin.

If brake disc corrosion is advanced and the brake pads are dirty (glazed brake area, blocked drain grooves), the discs and pads should be inspected, cleaned or repaired.

The brake system of your BMW should be checked regularly before and after the winter, possibly in conjunction with the prescribed inspection work.

We recommend you to consult a BMW dealer or any other qualified service and repair establishment without delay in the event of any problems occurring in the brake system.

important: Always have the brake fluid changed every year!

Antilock brake system (ABS)

BMW's unceasing efforts to improve its car's active safety have led to the development of the antilock brake system (ABS).

Whenever a brake application is made, the ABS is required to satisfy two fundamental requirements:

- a) To maintain the car's stability on varying surfaces (asphalt, concrete, mud, wet roads, snow and ice)
- b) To ensure that the car be steered and maneuvered under these adverse conditions.

These requirements must be seen in the light of certain essential accompanying factors.

Even ABS is unable to prevent the natural laws of physics from acting on the car. It cannot for instance avoid the consequences of braking when there is insufficient distance remaining to the car in front, when conserving limit speeds are exceeded or if there is a risk of aquaplaning (tires riding up on a cushion of water lying on the road surface). It remains the driver's task to judge speeds and brake applications correctly in such conditions.

The fact that the car may be equipped with ABS must never, despite the increased safety margins this system frequently affords, tempt the driver into taking risks which could affect his safety and that of other road users.

Driving a car equipped with ABS

After the engine has been started, the yellow **ANTI LOCK warning light** on the instrument panel will go out.

The system itself is then in working order, but does not come into action until road speed exceeds approx. 8 km/h (2.5 mile/h). After this minimum speed limit has been passed, the ABS can prevent the wheels from locking when the driver applies the brakes. If the speed drops below approx. 3 km/h (2 mile/h), the ABS will cease to operate, so that in theory the wheels could lock at the very end of a brake application, though in practice this is not critical at such a slow speed. The ABS regulating cycle is repeated over and over again within fractions of a second. To inform the driver that his brake application has caused the ABS to come into action, a pulsating effect is noticed at the brake pedal, together with a characteristic noise. As a warning to watch out for surfaces on which the tires cannot grip well, a "chattering" sound is heard when the ABS is controlling the braking pressure; this reminds the driver to reduce speed to suit the poor road conditions.

The ABS is capable of achieving the shortest possible braking distances in any given conditions (either in a straight line or when the steering wheel is turned, and on smooth asphalt, ice, wet roads etc.). The braking distance may be slightly longer on loose surfaces on top of a firm base, such as snow, since the skidding

wheels of a conventionally-braked car tend to build up a buffer of the loose materials as they are forced through it. This may also be the case if snow chains are fitted. However, the benefits of greater stability and the fact that the car can be steered more than outweigh this occasional slight drawback.

The ABS control unit incorporates an electronic fail-safe monitoring system which checks that all components are in working order before a journey, and repeatedly when the car is in motion. Any malfunction is indicated by the yellow Antilock warning light on the instrument panel coming on. The brake system then operates conventionally and with precisely the same standards of performance as on cars not equipped with ABS.

Tires

The factory-approved **radial-ply tires** have been chosen to suit BMW and provide both optimum road safety and the desired level of ride comfort.

The condition of the tires and maintenance of the **specified tire pressures** are vital factors affecting **tire life** and also **road safety** to a very high degree.

Tire pressures

Incorrect tire pressures are a frequent cause of complaints concerning tires. Furthermore, they may seriously affect the roadholding of your BMW.

Check tire pressure at regular intervals and before starting fairly long journeys, **but at least every two weeks**. Do not forget to check the spare tire as well: it should be kept at app. 0.3 bar (3–4 lb/in²) above the specified pressure for a fully-loaded vehicle.

If tire pressures are lower than specified, this will adversely affect road safety by reducing lateral locating force. The increased degree of tire sidewall flexing will lead to excessive heat build-up and thus introduce an element of risk into high-speed driving. Fuel consumption will be increased by the tire's greater rolling resistance, and tread wear will be more rapid.

If tire pressures are too high, ride comfort will suffer, the tire may lack grip and tread wear will again be rapid and uneven.

The tire valves are provided with **screw dust caps** to keep out dirt. If dirt enters the valve, a slow leak may result.

Tires have to withstand very severe loads at high speeds, particularly in hot weather and at the maximum weight limit for your car. Remember to increase tire pressures if loads are high, and not to exceed the **gross weight limit**.

For your own safety: check tire pressures regularly!

Tire treads – tire damage

Check the condition of the tires frequently: look for damage, stones and nails, premature wear and overall tread pattern depth.

The **tire tread** is regarded as acceptable by law in many countries if only 1 mm (0.04 in) deep, but it is advisable to renew tires when the tread depth has worn to 3 mm (0.12 in). Below this depth, there is a serious risk of aquaplaning at even moderately high speeds when the roads are apparently not too wet. If the tires wear down to 0.063 in (1.6 mm) tread depth, a **wear indicator** will become visible at the base of the tread pattern as a reminder that the legal limit of tire wear is approaching.

Always match your road speed to the condition of your tires – particularly the remaining tread depth – and to weather conditions.

Tire tread wear on the front wheels tends (for design reasons) to be slightly more rapid on the outer shoulders of the tire, whereas on the rear wheels it is concentrated more on the inner shoulders and the center of the tread. For this reason, the best and most consistent roadholding and grip are obtained if the tires are not

interchanged between the front and rear wheels, although overall tire life may then be slightly reduced.

On the other hand, we recommend that front and rear wheel alignment be checked once a year and whenever new tires are installed. Any exceptional rates of tire wear imply that wheel alignment is incorrect; this should be checked and repaired.

Tires must never have their treads re-grooved, in view of the risk of damaging the tire carcass.

Any **foreign body** (nail or similar sharp object) penetrating the tire may cause a slow puncture which will be recognized by the need to correct the tire pressure more frequently. In this event the tire should be checked and either repaired or renewed as soon as possible by your BMW dealer or a specialized tire workshop.

If, as a means of prolonging tire life, you wish to have the **wheels** rotated please bear the following in mind:

Due to the design principles of the front and rear axles and taking into account load and operating conditions, the front tires reach their wear limit first on the shoulders and the rear tires in the center of the tread. The higher the stresses (load, acceleration, lateral forces) the more wear will take place.

Drive at a moderate speed over poor road surfaces and approach unavoidable obstructions, such as a curb or severe bump in the road, with care so that the **inner structure** of the tire does not suffer internal damage invisible to you.

Take care not to bump the **tire sidewalls** when parking or driving onto loading ramps, car lifts etc.

Avoid overloading your BMW – especially on vacation trips. Overloading the vehicle can also exceed the tire's permitted load capacity and thus cause **premature or subsequent** damage.

Tire damage can be extremely dangerous for both yourself and other road users.

Replacing tires

Only tires of the same type and construction must be fitted on all four wheels. A mixture of cross (bias)-ply and radial-ply tires should not be used as it will alter the vehicle's handling properties.

Furthermore, in order to maintain the good ride and handling properties of your BMW all tires should be of the same make and tread pattern.

BMW does not approve of the use of remolded or retreaded tires owing to the possibility of differences in the tire carcasses and their sometimes very advanced signs of aging, which can have a detrimental effect on their durability and, under certain circumstances, the car's handling and safety.

Before undertaking any change to the tires on your car, please consult a BMW dealer concerning the practical value, legal position and factory recommendations.

A knowledge of tire and rim markings will help you make the right choice of tire. The following tire size designations are possible:

195/65 HR 14 85 H or
195/65 HR 14 85 T M + S***

195/65 H R 14 85 H

Tire width in mm
Cross sectional ratio in %
Speed rating code letter
Type code letter for radial
Rim diameter in inch*
(on TR – tires in mm)
Load rating code**
Speed rating code letter**

The speed rating code letters indicate the maximum permissible road speeds for summer tires (subject to legal limits):

S = up to 110 mile/h (180 km/h)

H = up to 130 mile/h (210 km/h)

* 1 inch = 25.4 mm

** only on R tires.

*** M + S = mud and snow

We recommend the **exclusive use of BMW-approved tires**.

Important: When replacing or changing tubeless tires, always replace the rubber valve as a safety precaution.

Changing the wheels from front to rear on the same side can in certain conditions have only a negligible effect on the service life whereas the handling and braking as well as the roadholding may be adversely affected.

If so desired the spare wheel can also be put into use. In this case one must remember that this wheel, possibly new, must be broken in and will at first not have the same degree of adhesion. Rotating the wheels must be done on the same side and at short intervals (max. 5000 km [app. 3000 miles]). During the following period a difference in roadholding and straight driving (possibly brake pulling to one side, smaller contact surface of rear wheels on the road) must be allowed for.

In the interests of your safety and optimum driving conditions we recommend that the wheels not be rotated, because the increase in service life is negligible. With non-standard wheels and tires the wheels should definitely not be rotated.

The following BMW wheels (rims) and tire sizes are factory-approved:

Radial-ply tires (tubeless)	Pressed- steel wheels	Run offset (dished depth)	Cast light alloy wheels	Run offset (dished depth)
BMW 528 e				
195/70 R 14 90 H	6 J x 14 H 2	0.87 in 22 mm	6 J x 14 H 2 6 1/2 J x 14 H 2	0.87 in 22 mm 0.87 in 22 mm
195/70 R 14 90 Q M+S	6 J x 14 H 2	0.87 in 22 mm	6 J x 14 H 2 6 1/2 J x 14 H 2	0.87 in 22 mm 0.87 in 22 mm
200/60 R 390 90 H TR 200/60 R 390 90 H M+S TR	165 TR 390	0.87 in 22 mm	165 TR 390	0.87 in 22 mm
BMW 535i/S				
195/70 VR 14	6 J x 14 H 2	0.87 in 22 mm	6 J x 14 H 2 6 1/2 J x 14 H 2	0.87 in 22 mm 0.87 in 22 mm
195/70 R 14 90 Q M+S	6 J x 14 H 2	0.87 in 22 mm	6 J x 14 H 2 6 1/2 J x 14 H 2	0.87 in 22 mm 0.87 in 22 mm
200/60 VR 390 TR 200/60 R 390 90 H M+S TR	165 TR 390	0.87 in 22 mm	165 TR 390	0.87 in 22 mm
BMW M 5				
220/55 VR 390			165 TR 390	0.87 in 22 mm
220/55 R 390 M+S*			165 TR 390	0.87 in 22 mm
225/50 VR 16 P 700**			7 1/2 J x 16 H 2	0.86 in 20 mm

* Winter tires

The M 5 is originally equipped with 225/50 VR 16 tires.

These tires do not provide sufficient clearance to allow the installation of snow chains. In order to be able to use snow chains you must first equip the car with a tire/rim combination of the size 220/55 VR 390 on 165 TR 390.

** On the tires 225/50 VR 16 the tire tread direction is indicated by means of an arrow on the sidewal.

When using the spare wheel and this direction cannot be observed you still have for all loads and speeds a totally safe wheel but in the interest of optimum driving conditions have the tire refitted as soon as possible.

We recommend the **exclusive use of BMW-approved tires.**

Use only **snow chains** according to SAE J 1232 classification "S". The snow chains may be used on drive wheels (rear by twos) only.

Before undertaking any **technical modifications** to your car, please consult a BMW dealer (quoting the chassis number) concerning the practical value, legal position and factory attitude to such modifications.

Any unauthorized modifications to your car may void your warranty. (See your warranty booklet).

Roof rack

To ensure the lowest possible roof loads and optimum drag characteristics, use only BMW-tested and -approved luggage and ski racks. When installing a **roof rack**, make sure that the mountings fit securely to the roof and are located as far apart as possible.

The roof load must be evenly distributed and not too large. Always stow the heaviest items at the bottom.

Make sure that luggage on the roof is tightly and properly secured, so that there is no danger of it shifting or even coming free during the journey. Consider the danger to other road-users.

Drive smoothly, avoiding jerky starts and sharp braking, and do not take corners and bends too fast.

Luggage on the roof increases the frontal area of the car, leading to higher fuel consumption and roof stresses.

It is recommended to take the luggage rack off the car when not needed.

PLEASE COMPLY WITH APPLICABLE STATE LAWS.

The **ski rack** (accessory) should be loaded so that the tail ends of the skis point forwards. Put only one pair of skis in each holder, with poles in the luggage compartment. Check all holders regularly.

Ski racks to match your car can be obtained from your BMW dealer.

Disc-type limited-slip differential

In very unfavorable driving conditions the conventional form of differential may be unable to transmit torque to the road wheels without wheelslip occurring. The limited-slip differential greatly reduces the undesirable and possible dangerous situation in which one driven wheel starts to spin.

In practice, this means that improved traction is provided when pulling away, accelerating and taking corners at speed in poor driving conditions.

At the same time, the car tends to spin around the vertical axis at the center of gravity at high power outputs and load reversals on slippery road surfaces. A good deal of skill is required to control a skid and extreme care must be taken especially when driving in an enthusiastic manner.

The locking action is produced by the friction of lined discs, and depends on the load exerted; the differential gear shafts, thrust rings and symmetrically located inner discs tend to move apart and brake the wheel generating the greater accelerative force.

As disc friction takes effect increasingly, it hinders or entirely prevents wheelspin on that side of the car, so that the other wheel can grip and keep the car moving.

A major advantage of the limited-slip differential is that it operates automatically when needed, and does not have to be engaged by the driver.

Care and maintenance

Your brand-new BMW is a splendid sight. Whether it stays that way, perhaps even for many years, depends on you, and on the care you are prepared to take.

Since the car's paintwork is exposed to so many potential environmental hazards, automobile manufacturers and paint suppliers are constantly working on further improvements to the strength and durability of modern paints.

The composition of the paints used by BMW, and the manner in which they are applied are to the very latest technical standards in this specialized field.

The manufacturer has used careful design techniques and the latest production methods for the body and other components to ensure that general upkeep of the car is simplified. The materials used were thoroughly tested in laboratories and under practical conditions before being approved, and are constantly being improved or updated as technical standards develop. This is BMW quality down to the last detail.

The high-gloss paint finish is not only chosen to appeal to owner's personal taste as far as the color is concerned, but also to provide maximum protection. It consists of **several layers** for reliable corrosion-proving; the **body cavities** are not only primer-coated by the cataphoretic dip process, but also coated with materials specially developed for this purpose in lengthy tests. The entire underside of the floor pan is given a sprayed-on, resilient PVC coating, followed by complete wax-based undersealing.

Every 12 months, during the **annual Check**, have the body including the underside of the floor pan examined by a BMW dealer. Full details are given in the Service- and Warranty-Booklet.

It is always more pleasant to drive a clean, well-kept car, but it is equally true to say that regular care and maintenance can make a big contribution to safety and to your car's resale value.

The points to watch are listed below.

A large number of external influences can affect the quality and appearance of your car's paintwork, some of them purely local in origin. They govern the amount of care the paintwork will need and how often it should be attended to.

Road dust and dirt, the airborne deposits encountered in industrial areas such as fly ash, lime and soot, even tar stains, dead insects, bird droppings and the stains left when the car is parked under trees all contain various chemicals which, if allowed to remain on for a long time, can damage the paintwork in the form of patches, blisters, corrosion, flaking paintwork and similar. The car should therefore be washed as often as necessary.

In **industrial areas**, the horizontal panels of the body in particular may suffer from deposits of fly ash, lime, oil soot or substances containing sulphur dioxide ("acid rain"), as well as other less easily identified deposits. Only regular care of the paintwork can avoid or minimize damage in such circumstances.

In **coastal regions** the high salt content and humidity of the atmosphere greatly increase the risk of body panel corrosion.

In the case of **mechanical damage** caused by sand, road salt, grit etc., the paint surface may be damaged or penetrated, and corrosion may then spread across the panel under the paint.

What you should know about paintwork care:

To protect the car from the start against gradual deterioration of the paintwork in areas of high atmospheric pollution or where "natural" substances in the air could damage the paint finish (industrial zones, railways, sap and resin from trees, pollen, bird droppings), it is important to **wash the car once a week**. In severe cases, wash the car whenever the paint finish appears to be dirty.

Remove spilled fuel, oil grease or brake fluid **at once**, as these substances can attack the paint or change its color.

Bird droppings should also be removed **without delay**, or they will damage the paintwork.

A new BMW can be put through an automatic car wash, or washed by hand, as soon as it begins to be used on the roads.

Dead insects should be soaked and wiped off **before** the main car wash.

Washing the car should be delayed if the engine compartment lid is still hot, or if the car has been parked or is still standing in strong sunlight, or else spots may form on the paint surface.

When using an **automatic car wash**, try to choose one without excessive brush pressure, and an ample supply of rinsing water. Most modern car washes satisfy these requirements. However, the areas not fully reached by the automatic system – door sills, panel folds and seams on doors and lid etc. – should be cleaned by hand.

During the cold season of the year in particular, it is advisable for the car to be washed more frequently, since the heavy dirt deposits and salt from wet roads are more difficult to remove and will damage the entire car if left on too long.

When the car is washed, take the opportunity to clean the interior and luggage compartment with a vacuum cleaner.

If you wash the car by hand, first soften the dirt deposits on the paint with a fine water spray, and rinse them off. Do not spray water directly into the air inlets or outlets of the heating/ventilation system.

After spraying down, wash the upper part of the body starting with the roof with a sponge, or similar item using plenty of cold or lukewarm water. Rinse out the sponge frequently.

Wash the lower part of the body and the wheels last, if possible keeping a separate sponge just for these areas.

After washing, rinse the car again thoroughly with a hose and dry it with a clean chamois leather to prevent discoloured spots where the water was not removed.

To protect the paintwork, a paint-care product can be added to the water used for washing the car.

If washing with water alone is insufficient, a car shampoo or similar cleanser which restores the fats content of the paintwork can be used in the concentration stated on the pack. After this, rinse with plenty of water.

Note: After washing, the brakes may be wet and therefore less effective in action. Apply them briefly to dry the discs.

Any localized dirt patches or other contamination of the paint surface can best be seen after the car has been washed. Remove them as soon as possible. Eliminate tar stains with a special tar remover.

Polish the paintwork at these points to restore its appearance and protect it.

Please use only **paint-care products** containing Carnauba or synthetic waxes, and comply with the instructions on the packs.

It is quite easy to decide when the car's paintwork needs polishing or preservative treatment: water no longer forms large round droplets and tends to roll off the surface. Depending on use of the car, this may arise after some 3 to 4 months. It is recommended to carry out the necessary protective treatment as soon as it becomes necessary.

If the paintwork tends to lose its high gloss as a result of insufficient care, a suitable **polish** must be applied. **Paint cleaner** is needed if the finish is already matt or weathered. An abrasive **polishing**

compound or paint restorer should only be used in very severe or obstinate cases. Remember that all polishes, cleaners or paint restorers act by removing a layer of paint and exposing paint which is still in good condition.

Only if the new paint surface is most carefully protected will the overall brilliance of your car's paintwork be regained.

After care of the car's paintwork, remove traces of the products used from the windows with a suitable glass cleaner.

Minor paint damage can be touched-up with either a paint spray aerosol or a paint stick, which is used like a brush. The correct paint color designation is on an adhesive label in the engine compartment.

Damage caused by flying stones, scratches etc. must be touched-up without delay, to prevent rust from forming.

If damaged areas of paintwork have already started to rust, use a wire brush to clean them up, and apply rust converter (protect the eyes and skin). Allow a few minutes for this to take effect, then rinse off with water and dry thoroughly. Apply primer and allow to dry, then apply the top coat. After a few days, polish the repaired area and apply a paint preservative.

More extensive paint damage should be professionally repaired in accordance with the manufacturer's instructions. The BMW Service Organisation knows and will apply the full repair procedure to ensure a permanent repair of good appearance.

Another important note:

If a tarpaulin or similar sheet is used to protect the car against the weather, moisture condensate may collect (particularly in the case of plastic sheet) and cause the plasticizers to diffuse out of the paint. There is also a severe risk of scratching the paint surface; it is far better to protect your BMW against ultraviolet rays from bright sunlight and against rainfall etc. by giving it the full body care treatment described above. Ideally, in countries where the sun is extremely hot and powerful a canvas sunsheet should be stretched above the car.

Annual cleaning and protection or treatment of the engine, engine compartment, underbody, axles and other mechanical assemblies can be carried out by your BMW dealer. This not only reduces the risk of serious corrosion to a minimum, but also avoids short-circuits caused by accumulated oil and dirt, and reveals leaks before they become severe. This treatment is particularly important at the end of the winter season.

Chromium-plated and polished metal parts – bumpers, trim strips, wheel trims etc. – should be cleaned regularly with water, to which a car shampoo can be added if required. Do not neglect this treatment in winter if salt is spread on the roads.

The car's **radio antenna** should be kept clean to ensure good reception, and can be given a coating of special antenna grease to protect it from the weather.

Important: This treatment is particularly advisable on motor-driven antennas.

Alloy wheels should be treated with a

special wheel-rim cleanser, particularly during the winter months. Do not use aggressive-action products containing acids, strong alkalis or abrasives. Alloy wheels should not be cleaned with a steam jet at a temperature higher than 140° F or 60° C.

The **inside surfaces of windows (and mirror glasses)** can be cleaned and smearing avoided with glass cleaner. Never clean mirror glasses with polishing pastes or abrasive (quartz) cleansers.

Plastic components, leatherette upholstery, roof linings, light lenses and items sprayed matt black should be cleaned with water to which a car shampoo may be added. Do not allow the roof lining to become wet right through. If necessary, apply a plastic cleaner to plastic components. Never use solvents such as nitro thinners, fuel etc.

Rubber components should only be cleaned with water or treated with a rubber cleanser or silicone spray.

To clean the **inside of the windows** we recommend a 1:1 mixture of water and vinegar.

Clean the **wiper blades** with soapy water. The wiper blades should be replaced twice a year, before and after the cold season.

Care of upholstery fabric

The **cloth** used by BMW is notable for hard wear, good heat transmission, freedom from sliding, a soft and attractive surface and easy care.

If certain areas of the seat acquire an unwanted gloss as a result of heat, friction and moisture, they should be brushed

“against the pile” with a slightly moistened brush.

The pile of velour material tends to lie flat in use: as with many furnishing fabrics and clothing materials, this is unavoidable and does not detract from its quality.

Fluff and loose threads or abraded leather particles on upholstery fabrics are best removed with a suitable lint brush. Clean off stains or large dirty marks at once with lukewarm water, car-interior cleaner or stain remover. Afterwards, brush the fabric to restore the pile.

The **upholstery leather** used by BMW on its cars is a high-grade natural product treated by the latest processes. If carefully looked after, it will retain its high quality for many years.

Regular cleaning and general care is essential, since dust and road dirt penetrate the pores and creases and cause the surface to wear away and become brittle.

Clean the leather surfaces with a slightly moist cotton or woollen cloth, but do not soak the leather right through at the seams. Dry the leather and rub it with a clean, soft cloth.

Very dirty areas on leather upholstery can be cleaned with a mild detergent (suitable for woollens) containing no brightening agents. Use 2 tablespoons to one liter (1 US quart) of water.

Unightly bald patches or minor surface damage can be rectified with leather spray lacquer.

If the car is parked for a long time in bright sunlight, it is advisable to cover the seats and the head rest, to prevent bleaching of the colours.

Stains on the interior trim upholstery – except for real or imitation leather – should be removed with a commercial foam spray. Brush down fabric surfaces afterwards. Rub plastic trim with a stiff sponge.

Wear patches on corduroy or velour fabrics are caused by pressure during frequent use and should be brushed 'against the pile' with a slightly moist brush.

Seatbelts should only be cleaned with a weak soap and water solution without removal from the car. Never attempt chemical or dry cleaning or else the fabric of the belts may be damaged.

Never allow **automatic** (inertia-lock) **seatbelts** to retract while they are still wet. Clean the seatbelts if they become dirty or muddy, as dirt penetrating the reel mechanisms could prevent them from locking or keeping the belts taut and thus constitute a safety risk.

Engine and performance data

	BMW 528 e		BMW 535i/S		BMW M 5	
Displacement – effective	164.3 in ³	2693 cm ³	209.0 in ³	3428 cm ³	210.6 in ³	3453 cm ³
Max. output at engine speed	121 hp 4250 rpm	90 kW	182 hp 5400 rpm	136 kW	256 hp 6500 rpm	191 kW 6500 rpm
Max. torque at engine speed	170 ft/lb 3250 rpm	230 Nm	213 ft/lb 4000 rpm	290 Nm	239 ft/lb 4500 rpm	330 Nm 4500 rpm
Compression ratio	9.0 : 1		8.0 : 1		9.8 : 1	
Stroke/bore	3.19/3.31 in 81/84 mm		3.38/3.62 in 86/92 mm		3.30/3.67 in 84/93,4 mm	
Cylinder	6		6		6	

Performance data	BMW 528 e		BMW 535i/S		BMW M 5	
Top speed – manual gearbox	114 mph or 184 km/h		134 mph or 215 km/h		150 mph or 241 km/h	
Top speed – automatic transmission	111 mph or 179 km/h		130 mph or 209 km/h			
Acceleration						
0–50 mph/0–80 km/h	7.4 sec	9.1 sec*	5.7 sec	6.8 sec*	5.0 sec.	
Standing start 1/4 mile in	17.8 sec	18.9 sec*	16.1 sec	17.1 sec*	15.0 sec.	

* Automatic model

Dimensions and weights

	BMW 528e	BMW 535i/S	BMW M 5
Length		189.0 in or 4800 mm	
Width		66.9 in or 1700 mm	
Height (unloaded)		55.7 in or 1415 mm	
Wheelbase		103.3 in or 2625 mm	
Front overhang		39.2 in or 995 mm	
Rear overhang		46.5 in or 1180 mm	
Front track		56.3 in or 1430 mm	
Rear track		57.5 in or 1460 mm	
Min. turning circle (wheels)		0.39 ft or 10.0 m	
Min. turning circle (overall)		0.44 ft or 11.1 m	
Unloaded weight (ready for road, tank full) according to FMVSS 110	3075 lb or 1395 kg *	3250 lb or 1474 kg *	3420 lb or 1551 kg
Permissible gross weight	4115 lb or 1866 kg *	4285 lb or 1943 kg *	4390 lb or 1191 kg
Permissible front axle load	2005 lb or 910 kg	2115 lb or 959 kg	2115 lb or 960 kg
Permissible rear axle load	2270 lb or 1030 kg	2335 lb or 1059 kg	2335 lb or 1060 kg
Maximum vehicle load		1015 lb or 460 kg	970 lb or 440 kg
Permissible roof load		165 lb or 75 kg	

* For automatic transmission models add 20 kg/44 lb.

Ratios**Transmission ratios**

	Manual	BMW M 5	Auto- matic
1st	3.83	3.51	2.48
2nd	2.20	2.08	1.48
3rd	1.40	1.35	1.00
4th	1.00	1.00	0.73
5th	0.81	0.81	–
Reverse	3.46	3.71	2.09

Rear axle

Ratio:	
BMW 528e	2.93:1
BMW 535i/S	3.25:1
BMW M 5	3.91:1

Electrical system

Alternator 14 V, 90 A

Starter 1,5 kW, 12 V

Spark plugs

Bosch WR 9 LS

Bosch X 5 DC (BMW M 5)

Spark plug gap 0.027 + 0.004 in or
0.7 + 0.1 mm

0.024 + 0.004 in or 0.6 + 0.1 mm
(BMW M 5)

Headlights

High beams: 2 halogen sealed beam units

Low beams: 2 halogen sealed beam units.

Battery

BMW 528e, 535i/S 12 V, 75 Ah

BMW M 5 12 V, 90 Ah

Firing order 1–5–3–6–2–4

Warning:**Digital Motor Electronics**

This is a high-performance ignition system, and it is highly dangerous to touch any ignition-components when the engine is running.

Index

- Acceleration values 71
- Air conditioning 28, 78
- Air extraction 27
- Air outlet grilles 26
- Alternator 73
- Antenna 39, 69
- Antifreeze 59
- Antilock brake system 62
 - Warning light 21
- Ashtrays 29
- Automatic transmission 24
 - oil level check 47
 - oil content 77
 - ratio 73
- Automatic transmission selector lever 24
- Axle loads 72

- Backup lights 24
- Battery 49, 73
- Battery acid level 49
- Battery charge telltale 21
- Blower control 27
- Body cavity sealing 67
- Body dimensions 72
- Body overhang 72
- Brakes 42, 61
- Brake and clutch hydraulic fluid level check 48
- Brake fluid renewal 48
- Brake fluid level warning light 21
- Brake lining wear indicator telltale 21
- Brake (stop) lights 58
- Brake pads 42
- Break-in hints 41
- Bulb changing 55

- Capacities 77
- Care of car 67
- Catalytic converter 41
- Center brake (stop) light 58
- Central locking system 9
- Central warning light 22
- Cigarette lighter 29
- Circuit breaker 31
- Chassis number 44
- Check control 22
- Child proof safety catch 10
- Child restraint system 13
- Chromium, care of 69
- Clock 33
- Cold starting 40
- Cold weather operation 59
- Compression ratio 71
- Coolant level check 48
- Coolant compensating tank 48
- Coolant temperature gauge 20
- Cooling system capacity 77
- Cruise control 32
- Cylinders, number of 71

- Differential, see Rear axle
- Dimensions 72
- Dimmer switch 17
- Disc brakes 61
- Disc-type limited slip differential 66
- Displacement (engine) 71
- Door locks 9
- Door mirrors 15
- Driver's seat adjustment 11
- Driving hints 43, 60, 61

- Economy 4
- Electric seat adjustment 12
- Electric seat heating 29
- Electric window lift 30
 - manual operation 54
- Electrical system 73
- Electromechanical locking system 9
- Emission control system 41
- Energy-conscious driving 4
- Engine capacity 71
- Engine compartment at a glance 45
- Engine compartment lock 43
- Engine data 71
 - oil change 46
 - oil consumption 45
 - oil content 77
 - oil grades 46
 - oil specification 46
 - power output 71
 - specifications 71
- Evaporative Emission Control system 41

- Fasten seat belt warning light 13
- Filling capacities 77
- Firing order 73
- Flashlight 30
- Fog light switch 23
- Foot brake 61
- Fresh air grilles 26
- Front seat adjustment 11
- Front turning lamps 56
- Fuel 5, 42
- Fuel and lubricants 46, 77
- Fuel consumption indicator 19
- Fuel economy 4
- Fuel filler flap 5, 10
- Fuel gauge 20
- Fuel quality 5, 42
- Fuel reserve 20
- Fuel tank capacity 77
- Fuses 50

- Gearbox gate pattern 24
- Gearbox oil capacity 77
- Gearbox oil grades 77
- Gearbox ratios 73
- Glove box 30

- Hazard warning flashers 23
- Head and side marker light switch 56
- Headlights 55
 - switch 16
- Headrests 11

- Heated rear window 23
- Heating and ventilation 26
- Height 72
- High beam flasher 17
- High beam headlights 17, 73
- Hood 43
- Horns 18

- Ignition/starter switch 16
- Instrument light 16
- Instrument panel 17
- Interchanging wheels 64
- Interior light 57
- Interior switch 29
- Interior mirror 15
- Intermittent wiper action 18

- Jack 52
- Jump starting 50

- Keys 9
- Kick-down 25

- Leather 69
- Length 72
- License plate lights 58
- Lifting points for vehicle hoist 53
- Lighter 29
- Limited slip differential 66
- Locks 9
- Low beam headlights 73
- Luggage compartment 10
- Luggage compartment light 10, 57
- Luggage compartment lock 10

- Manual transmission 24
 - oil content 77
- Map reading light 15
- Mirrors 15
- Modifications, technical 65

- Octane number 5
- Oil additives 46
- Oil content 77
- Oil level, checking 45
- Oil pressure warning light 21
- On-board computer 33
- Overhang 72
- Oxygen sensor 41

- Parking brake 23
 - lights 16, 56
- Performance 71
- Pick-up points 53
- Power output 71
- Power socket 29
- Power steering 47
 - oil content 77
 - oil level check 47
- Power windows 30, 54
- Punctures 52

- Radial-ply tires 65, 78
- Radio 39
- Rear axle 73
 - oil content 77
 - oil grades 77
 - ratio 73
- Rear lights 56
- Rear side marker 57
- Reverse gear, selecting 25
- Reversing lights 24
- Roof load 72
- Roof rack 66

- Screenwasher, see windshield
 - wipe-wash lever
- Seat adjustment 11
- Seat belts, automatic reel 13
- Seat heating 29
- Service indicator 20
- Shift pattern diagram 24
- Side marker lights 16, 56

- Ski rack 66
- Sliding/vent sun roof 31
 - manual operation 55
- Snow chains 60, 65
- Spark plugs 73
- Spare tire 52
- Speedometer 19
- Sports seat 12
- Starter 73
- Starting aids 50
- Starting difficulties 51
- Starting the car 40
- Steering column, adjusting 12
- Steering lock 16
- Steering, oil level check 47
- Stop lights 58
- Storage out of use 59
- Stroke/bore 71
- Sun roof 31
- Sun visor 15
- Supplementary Restraint System (SRS) 14

- Tachometer 19
- Telltale lights 21
- Tires 63
- Tire sizes 65
- Tire inflation pressures 78
- Tool kit 51
- Top speed 71
- Torque 71
- Tow starting 51
- Towing away 52
- Towing eyes 51
- Track 72
- Transmission ratios 73
- Tread wear indicator 63
- Trip odometer 19
- Turn indicator lever 17
- Turning circle 72

- V-belts 78

Vehicle care 67
Ventilation 26

Warning gong 13
Warning lights 21
Washer fluid tank 49
Weight 72
Wheelbase 72
Wheel changing 52
Wheel chock 52
Wheel stud wrench 52
Wheels 65
Width 72
Window lift circuit braker 31
Window lift switches 30
Windows, manual operation 54
Windshield wipe-wash lever 18
Windshield washer fluid tank 49
– capacity 77
Windshield washer jets 49
Winter operation 59
Winter tires 60
Wipe-wash lever 18
Wiper arms 54
Wiper blades 54



Filling capacities

		Notes
Fuel tank	16.6 US gal/63 liters/ 13.8 Imp. gal	Unleaded gasoline (87 AKI or 91 RON)
Tank for windshield washer	3.2 US quarts/3.0 liters 5.3 Imp. pints	For details, see pages 49
Cooling system including heater circuit BMW 528e	11.6 US quarts/11 liters/ 19.4 Imp. pints	For details, see page 48
Cooling system including heater circuit BMW 535i/S, M 5	12.7 US quarts/12 liters/ 21.1 Imp. pints	
Engine oil BMW 528e	4.2 US quarts/4 liters/7.0 Imp. pints + 0.26 US quarts/0.25 liters/0.44 Imp. pints if oil filter is changed	Reputable 4-stroke HD gasoline- or diesel engine oil, rated SE or higher. For oil grades, see page 46
Engine oil BMW 535i/S, M 5 (BMW M 5) After repair, if oil cooler was emptied	5.3 US quarts/5 liters/8.8 Imp. pints + 0.8 US quarts/0.75 liters/1.3 Imp. pints + 0.8 US quarts/0.75 liters/1.3 Imp. pints in addition to the above amount	
Manual transmission BMW M 5	1.7 quarts/1.6 liters/2.8 Imp. pints** 1.3 quarts/1.25 liters/2.1 Imp. pints*	Reputable non-hypoid gearbox oil, SAE 80 specification MIL-L-2105 or API-GL 4, alternatively single-grade HD engine oil (mineral oil based) SAE 20/30/40, specification API-SE or SF. For usage of synthetic lubricants contact your BMW dealer. * Oil grade: Mobil SHC 630 ** BMW 528e, ATF-Oil
Automatic transmission	For oil change: app. 3.2 US quarts, 3 liters, 5.3 Imp. pints	Use only reputable automatic transmission fluids of Dexron formulation.
Rear axle Rear axle BMW 535i/S, M 5	1.9 US quarts/1.8 liters/3.2 Imp. pints 2.0 US quarts/1.9 liters/3.3 Imp. pints	Reputable hypoid gear oil SAE 90 (GL-5)

Service station information

V-belts BMW 535i/S/528e/M 5

Alternator and Water pump

BMW 535i/S/M 5	12.5 x 1055
BMW 528e	9.5 x 965

Power steering pump



BMW 535i/S/M 5	9.5 x 888
BMW 528e	9.5 x 825

Air conditioning compressor

BMW 528e/535i/S	12.5 x 810
BMW M 5	12.5 x 800

For your own safety – check tire pressures regularly

Tire pressures in bars (psi) when cold (ambient temperature). On warm tires the pressure can rise for about 0.3 bar (app. 4 psi). Changes in temperature vary the tire pressure (10° C/18° F = 0,1 bar/1,5 psi)

BMW model	Radial-ply tires, tubeless	max. 			
		Front	Rear	Front	Rear
528 e	195/70 R 14 90H	2.0 (29)	2.0 (29)	2.2 (32)	2.5 (36)
	195/70 R 14 90Q M + S				
	200/60 R 390 90H TR				
	200/60 R 390 90H M + S TR				
M 5	220/55 VR 390	2.6 (37)	2.8 (41)	3.0 (43)	3.5 (50)
	220/55 R 390 93H M + S	2.4 (35)	2.4 (35)	2.6 (37)	3.0 (43)
	225/50 VR 16 P 700	2.5 (36)	2.7 (40)	2.6 (37)	3.1 (44)
535i/S	195/70 VR 14*				
	195/70 R 14 90Q M + S	2.3 (33)	2.3 (33)	2.4 (35)	2.5 (36)*
	200/60 R 390 90H M + S TR*				
	200/60 VR 390 TR				2.9 (42)

* When your vehicle is operated **outside** the USA and Canada at speeds in excess of 180 km/h or 110 mile/h (law permitting), the air pressure in the tires should be risen for 0,4 bar (6 psi).

Your vehicle is equipped with tires which not only meet US standards, but also European standards. We recommend the **exclusive use of BMW-approved tires**.

The speed rating code letters indicate the maximum permissible road speeds for summer tires (subject to legal limits):

S = up to 110 mile/h (180 km/h) Winter tires, speed cat. Q – 100 mile/h (160 km/h)
 T = up to 118 mile/h (190 km/h) Winter tires, speed cat. T – 118 mile/h (190 km/h)
 H = up to 130 mile/h (210 km/h) Winter tires, speed cat. H – 130 mile/h (210 km/h)
 V = over 130 mile/h (210 km/h)

Use only snow chains according to SAE J 1232 classification "S". The snow chains may be used on drive wheels (rear) by twos only.